

05/2024

VVA VERLAG  
Cologne /Germany



# EXTRUSION INTERNATIONAL

USA

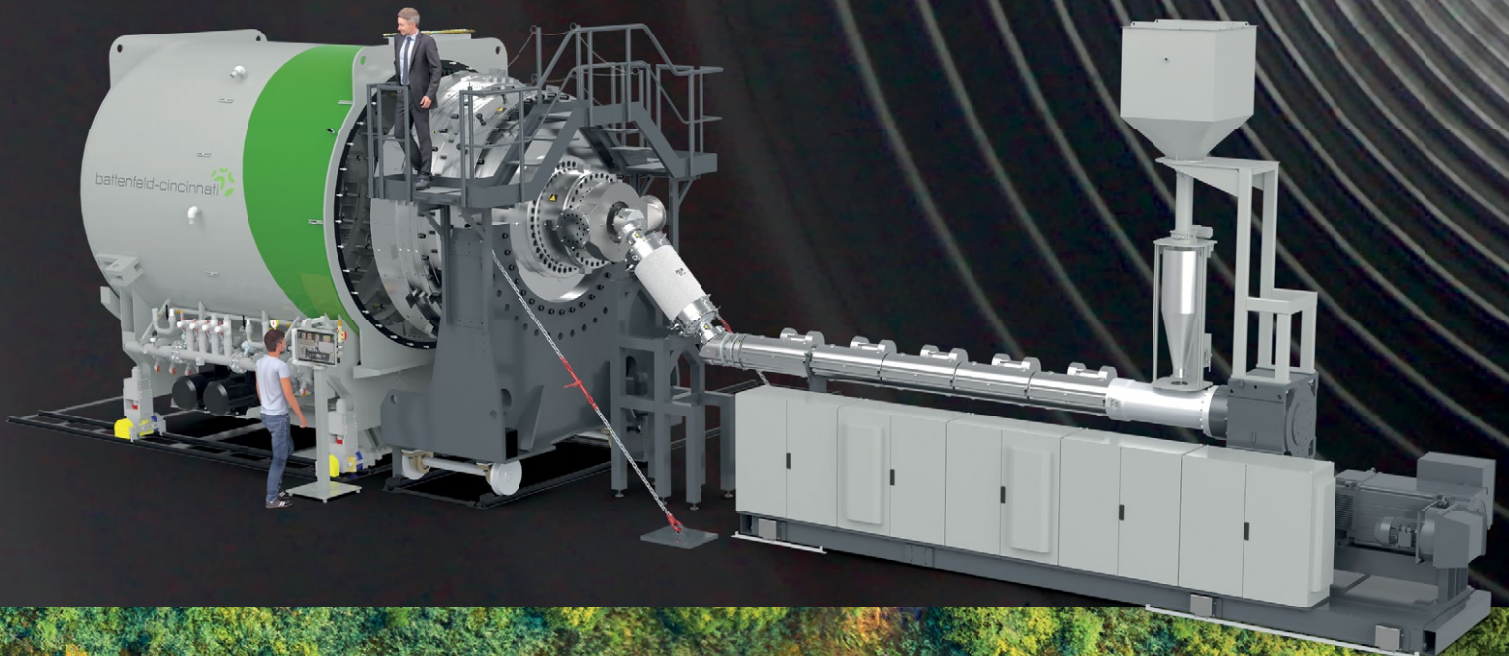

## PO Pipe extrusion 2,7 m line

- Output capacity up to 2500kg/h
- Die head with optimelt system
- Newly designed vacuum & cooling tanks

[www.battenfeld-cincinnati.com](http://www.battenfeld-cincinnati.com)

Process engineering for  
efficient plastics extrusion  
of tomorrow.

battenfeld-cincinnati  
a Davis-Standard Company



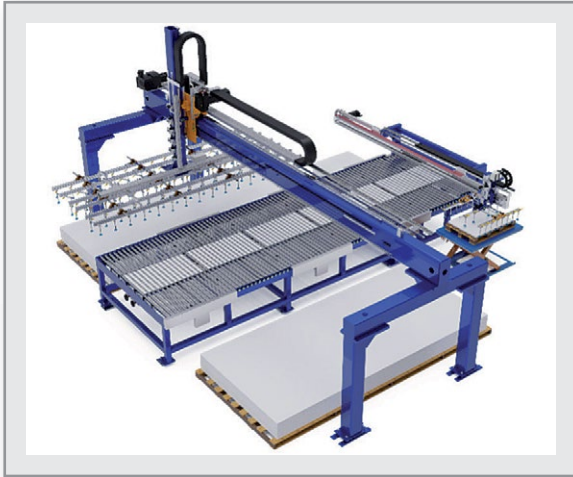

### Plate Stacking Machine

for automatic depositing of your production plates on transport pallets or trolleys.

Optional available with:

- Additional stacking places
- Spreading device of sheets side by side
- Separation of consecutive panels for simultaneous stacking

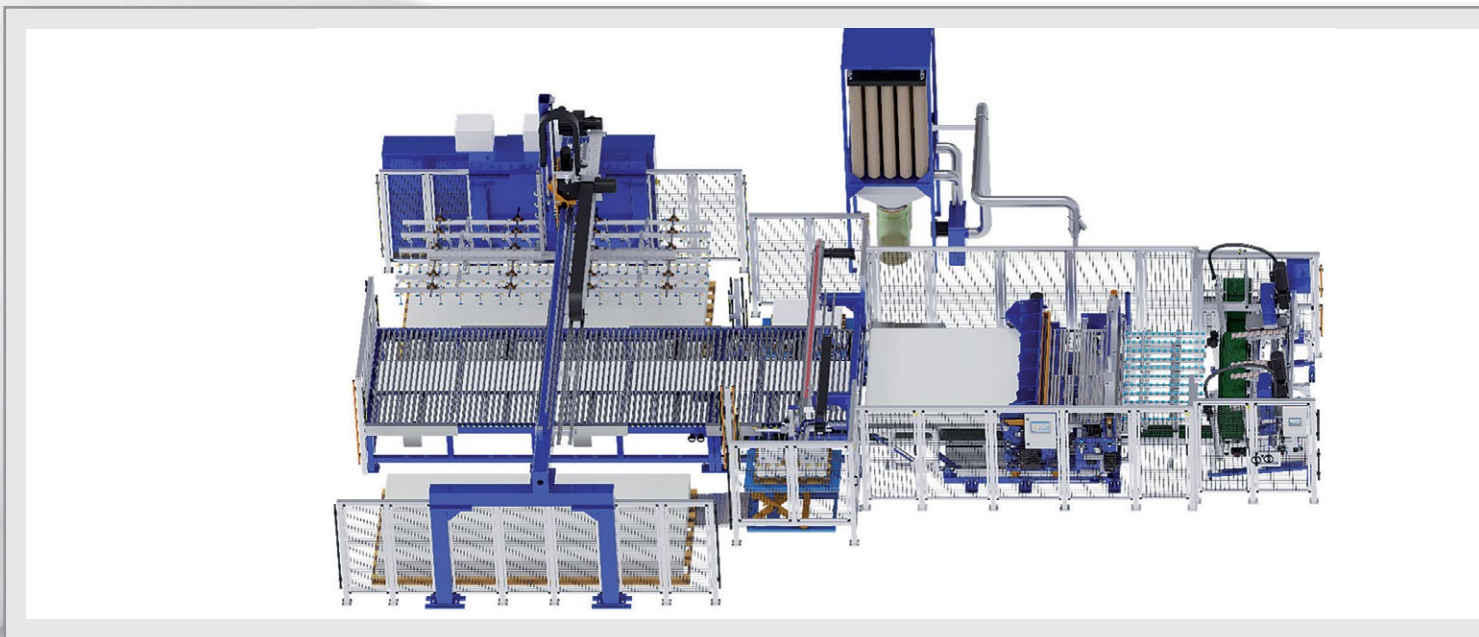

### Cross Cutting Combination

enables optional sawing or cutting in one machine.

Optional available with:

- Hydraulic driven scissor
- Electric driven scissor
- Cross Cut Mill instead of saw
- Cutting angle adjustment



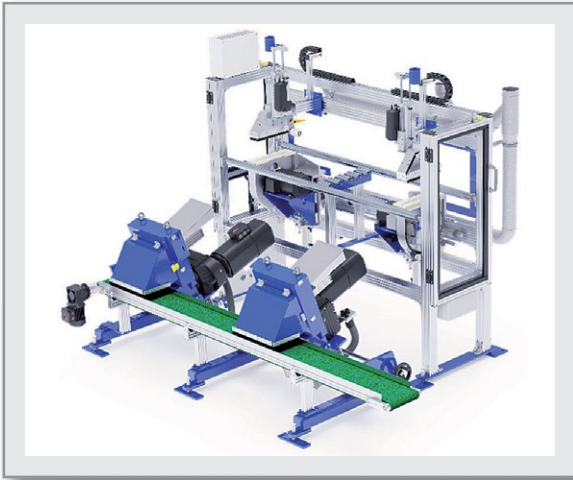

### Edge Trimming Saw & Trim Strip Chopper

an unbeatable team for longitudinal cutting of your panel and direct shredding of the resulting return material.

The machines are also offered individually with many options.

As a specialist in the field of special machine construction, we always find a solution!



### Pull Off Roller

provides precise regulation and compliance of roller speed and roller force.

#### Optional available with:

- Automatic material run control
- Selection of roller coatings
- Multiple Pull Off Roller version

### Calender

for continuous dimensional accuracy and surface quality.

#### Key data:

- Throughput capacity depending on material 400 - 1300 kg/h
- Line speed 0,5 - 70 m/min
- Line pressure per roller: 100-1300 N/cm



### STEIN Maschinenbau GmbH & Co. KG

Wartbachstrasse 9  
66999 Hinterweidenthal/Germany  
Tel. (+49) (0)63 96-9215-0  
Fax (+49) (0)63 96-9215-25  
stein@stein-maschinenbau.de  
www.stein-maschinenbau.de

## CONTENTS

Firms in this issue	6	Recycling is Real' Marks One-Year Milestone with New Video	34
Imprint	7	Plans to Close Manufacturing Site in Singapore Announced	34
<b>Industry News</b>	8	Economic Analysis: Revised Employment Statistics Impact on Plastics	35
Calendar	8	Winner of the Plastics Industry Association Bioplastics Innovation Award	35
Plastics Hall of Fame Gala to be Held Outside the USA for the First Time	8	<b>Fakuma 2024 –</b>	
New Website Launched	9	Flying High and More: Fascinating Highlights at Fakuma 2024	36
New Sales Office Opened in Singapore	9	Cutting-Edge Solutions for Efficiency and Sustainability	38
Personalia	10	Versatile Recycling Technologies to Meet Increasing Expectations	40
Organizational Integration after more than 35 Years of Successful Sales and Service Partnership	10	New Series of OMNI Recycling Lines – Revolutionary Degassing and Decontamination Technologies Open Up Expanded Application Opportunities	41
Food Safety Management Certified	12	Benchmark in Standard Compounds	43
Sustainable Plastics Solutions	12	Forward-Looking Digital Solutions for the Extrusion Industry	44
New Compact Design FFU Universal Gate Valve	14	ISEC evo also Keeps Composite Materials in the Loop	45
Lumps and Neckdowns have No Place in the Filament	14	High-Efficiency Technologies For Processing And Recycling Plastics	46
In-line Quality Control for Plastic Recyclate	15	Auxiliary Equipment and Automation	48
Series of High-Performance Blown Film Line Launched	16	Sustainable Solutions for Mixing, Foaming and Cooling	50
Comprehensive Expertise United Under One Roof	17	Plasma Treatment	51
Partnership with AI Start-up	18	Material Solutions for Thermal Management of EVs, Recycling and 3D Printing	51
Production Reliability Maximized by Uninterruptible Power Supply for Printers	19	Focus on Innovative Technologies and New Products	53
New HiQuad® Neo Mass Spectrometer	20	Recycling & Defossilization	54
Biopolymers Portfolio Expanded	21	Latest Developments in Advanced Mold Temperature Control Units and Adiabatic Cooling Solutions	55
Blow Molding Dies	22	Ready to Stand Out? – High-Quality Colour and Additive Concentrates	56
Market Study – Plastic Pipes	22	Raw Materials	56
Baby Bottles – Safe and Robust	22	Innovative and Sustainable Engineering Solutions for the Products of Tomorrow	57
Sustainability Report	23	<b>Processing, Recycling</b>	
Reusable PET Bottle for Cosmetic Products	24	Double Filtration in Plastics Recycling – More Than a Trend	58
Innovative Foreign Body Detection using X-Ray Technology	24	<b>Bio-Based Plastics – From the Research</b>	
Vacuum and Leak Detection Solutions Introduced	26	Innovative Plastic Film Material Made from PLA Bioplastics	59
Portfolio Expanded	27	<b>Measurement Technology – Case Study</b>	
NEW 500 Series Rubber/Silicone Extrusion Crosshead	28	Optimising Production Efficiency through Precision and Automation	61
Standardized OPC UA Data Exchange for Peripheral Devices	28	<b>Measurement Technology, Blown Film</b>	
New Management	29	Market Launch of the KNC-401 Online Thickness Sensor for Blown Film Lines	62
<b>Industry News USA</b>	30	<b>Measurement Technology</b>	
wire MEXICO 2025 Dates Announced – Debut of Tube Mexico	30	„Measuring Technology meets Gravimetric Weighing“	64
2024 Size and Impact Report: Plastics Industry Thrives, Vital to Job Creation, Economic Growth and Manufacturing	30	<b>Extrusion Technologies – Interview</b>	
Statement on Investments for New Recycling Sites in California	31	„Primary Focus is on Circular Economy Solutions“	65
Introduction of Bipartisan Legislation to Modernize Recycling Infrastructure Applauded	31		
New ASM for the Americas Appointed	31		
50 Years of Operational Excellence Celebrated	32		
Radiation Service Provider Expands into the USA	32		
New Managing Director for Americas	33		



# Cover

## The battenfeld-cincinnati Group

The battenfeld-cincinnati group develops, designs and produces customized extruder and complete extrusion lines for companies in a wide range of industries – from the construction industry to water management. The innovative extrusion solutions are used in various applications in the areas of pipe, profile, sheet, board, thermoforming sheet and pelletizing. Established in the 1940s, battenfeld-cincinnati is one of the oldest companies in this sector and has production facilities in Germany, Austria, China and USA. battenfeld-cincinnati is dedicated to research and development in order to continuously offer new and improved solutions for plastics extrusion. Sustainability and energy efficiency are at the center of the innovation strategy.

battenfeld-cincinnati is a Davis Standard Company, USA, and stands for quality in plastics extrusion as reliable partner for customers worldwide.

**battenfeld-cincinnati Germany**  
[www.battenfeld-cincinnati.com](http://www.battenfeld-cincinnati.com)



The Gneuss MRS Extrusion Technology is well known as an alternative for the recycling of contaminated materials such as Polyester, Polystyrene, Polypropylene or Polyethylene. In combination with Gneuss' Rotary Filtration Systems, optimised vacuum technology, an Online Viscometer VIS and measurement technology, customisable recycling lines can be designed for a specific material



In the face of growing environmental concerns and regulatory pressures, the plastics industry is undergoing a significant transformation. Central to this change is the adoption of more advanced recycling technologies. FIMIC has a proven double filtration technology that allows to process heavily contaminated plastic waste streams, with only one machine and two filtration steps

Flexible, disposable plastic films used in shopping or garbage bags are made mainly from petroleum-based low-density polyethylene. These films come with a large carbon footprint and contribute to environmental pollution. A team from the Fraunhofer IAP has developed a flexible and recyclable plastic film material based on polylactide bioplastic and paved the way for its commercialization

How do you manage to fly over a wobbling bubble of film with a capacitive thickness sensor at a distance of a few tenths of a millimeter, measure its thickness with micrometer precision and leave no traces behind? Kündig Control Systems (KCS) has been tackling this challenge for over 20 years and is about to launch its latest film thickness sensor, the KNC-401

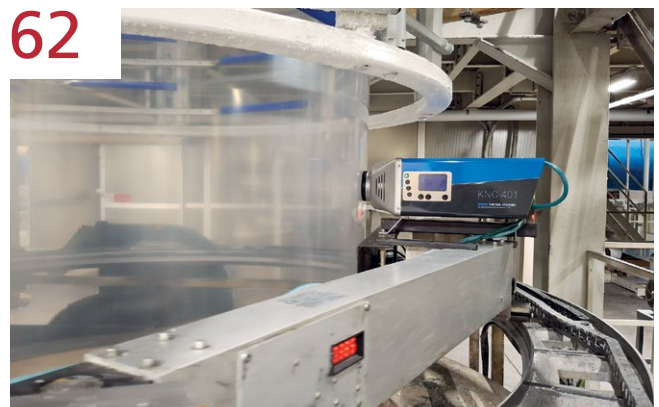

## Index of Advertisers, companies and fairs referred in this issue

AF-COLOR	56	Leibinger, Paul	19
ALPLA	24	Leistritz	44
Asahi Kasei	51	Meraxis	18
Balzanelli	13	Messe Düsseldorf	8, 30
BASF	20, 22	Moretto	29, 48
battenfeld-cincinnati	Outside Cover	motan	7, 38
BGS	32	M.TEC	57
BUSS	9	Nordmann, Rassmann	56
CCA	19	Orion	23
Ceresana	22	Pfeiffer Vacuum	20, 26
CONEXTRU	11	PlasMec	27
CONTREX	29	PLASTICS	30, 35
Coperion	14, 17, 46	pmh	14
Ensinger	12	POLYMERIZE	18
EREMA	40	Promix	50
Erge	49	PURE LOOP	45
Euromap	28	Rajoo	16
Fakuma 2024	36	Recycling is Real	34
Feddem	53	Reifenhäuser	10
Feddersen, K.D.	27	Schall, P.E.	36
Ferrari & Benelli	51	Schönenberger, H.	39
FKuR	54	Sesotec	10, 24
FIMIC	25, 58	SI	32, 34
Fraunhofer IAP	59	Sikora	14, 47, 64
FRIGEL	55	SKZ	15
Gneuss	41	Smart-Extrusion	Outside Back Cover
Guill Tool & Engineering	9, 21, 28	SML	35
Hellweg Maschinenbau	43	Stein Maschinenbau	Inside Front Cover+3
Herbold Meckesheim	15, 46	Thyseed	22
iNOEX	61	Tosaf	12
K 2025	8	Tube Mexico	30
KIEFEL	29	Useon	65
Koch Technik	37	Vetaphone	31
KRAIBURG TPE	33	VM Verlag	Inside Back Cover
KÜNDIG	21, 62	wire Mexico	30
Lehmann&Voss	43	Zumbach	17

# MEDIA DATA 2025

MAGAZINE · WEBSITE · NEWSLETTER

# EXTRUSION

EXPERT MEDIA ON PLASTICS EXTRUSION

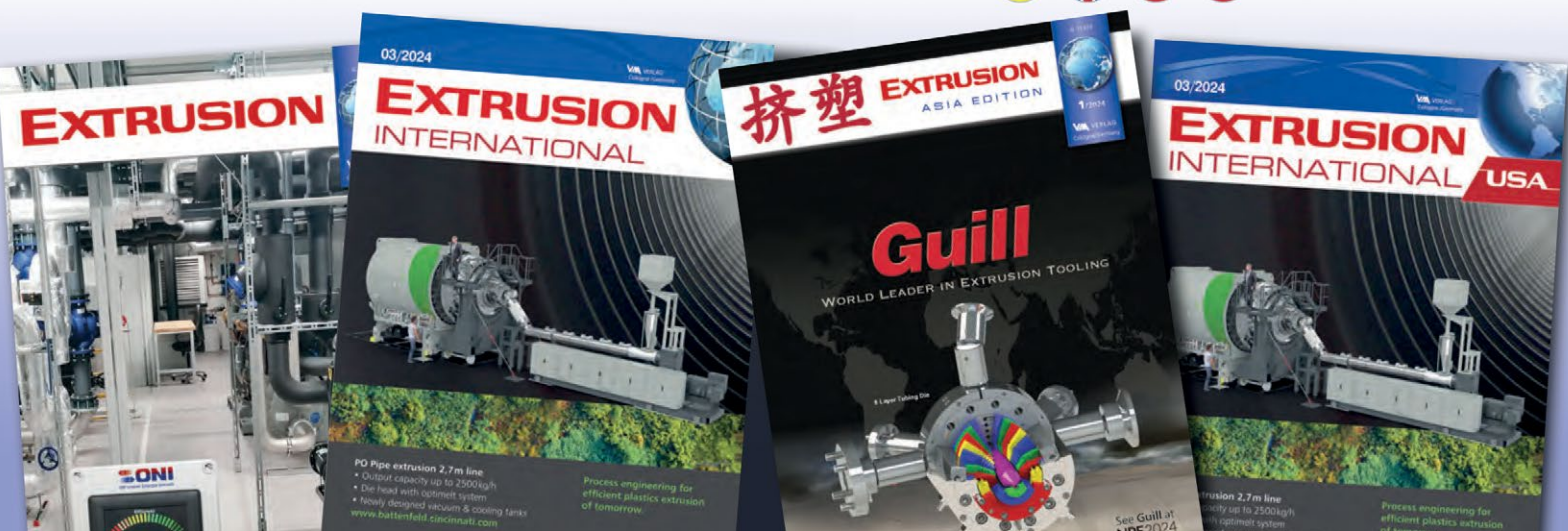



The Extrusion International Magazine is published bimonthly by VM Verlag GmbH. P.O.Box 501812, D- 50879 Cologne, Germany

**EDITOR**

Bettina Jopp-Witt (Editor-in-chief)  
T. +49 221 546 1539  
redaktion@vm-verlag.com

**ADVERTISING SALES**

Martina Lerner  
T.+49 6226 971515  
lerner-media@t-online.de

Tanja Bolta  
t.bolta@vm-verlag.com  
+49 15205626122

**ADMINISTRATION**

Alla Kravets  
T. +49 2233 949 8793  
a.kravets@vm-verlag.com

**PRINTING**

maincontor GmbH  
Dr.-Gammert-Str. 13a,  
63906 Erlenbach, Germany  
T.: +49 937294810811  
www.maincontor.de,  
info@frankhohmann.com

**SALES REPRESENTATIVES**

China & Asia  
octavia@ringier.com.hk,  
T. +852-9648-2561  
maggieliu@ringiertrade.com,  
T. +86-13602785446

Tokyo PR Inc. (Japan)  
T. +81 (3) 3273-2731  
extrusion@tokyopr.co.jp

**Reprints, Translation etc**

No part of this publication may be reproduced, stored in a retrieval system, or transmitted, in any form or by any means, electronic, mechanical, photographic, recording or otherwise, without prior permission of the publisher.

[www.smart-extrusion.com](http://www.smart-extrusion.com)



# sDRY

Compact dry air dryer for one or more drying bins.

Please visit us:  
Hall B1, Stand 1111  
15th - 19th October 2024



**ZERO LOSS**

[www.motan-group.com](http://www.motan-group.com)



#### Fakuma 2024

15 - 19 October 2024  
Friedrichshafen / Germany  
[www.fakuma-messe.de](http://www.fakuma-messe.de)

#### Swop – Shanghai World of Packaging

18 – 20 November 2024  
Shanghai / P.R. China  
[www.swop-online.com/en/](http://www.swop-online.com/en/)

#### Plast Eurasia 2024

04 - 07 December 2024  
Istanbul / Turkey  
[plasteurasia.com](http://plasteurasia.com)

#### ICE Europe 2025

11 - 13 March 2025  
Munich / Germany  
[www.ice-x.com](http://www.ice-x.com)

#### PLASTIMAGEN

11 – 14 March 2025  
Mexico City / Mexico  
[www.plastimagen.com.mx/es](http://www.plastimagen.com.mx/es)

#### CHINAPLAS 2025

15 - 18 April 2025  
Shenzhen / P.R. China  
[www.chinaplasonline.com](http://www.chinaplasonline.com)

#### K 2025

08 - 15 October 2025  
Düsseldorf / Germany  
[www.k-online.de](http://www.k-online.de)

#### interpack 2026

07 - 13 May 2026  
Düsseldorf / Germany  
[www.interpack.de](http://www.interpack.de)

#### Interplas 2026

02 - 04 June 2026  
Birmingham / United Kingdom  
[www.interplasuk.com](http://www.interplasuk.com)

#### Equiplast

02 – 05 June 2026  
Barcelona / Spain  
[www.equiplast.com](http://www.equiplast.com)



## Plastics Hall of Fame Gala to be Held Outside the USA for the First Time

■ For the first time, the induction ceremony of the “Plastics Hall of Fame Class of 2025” will be held outside the USA. The ceremony will take place on 7 October 2025, the eve of K 2025, the world-leading trade fair for plastics and rubber, in Düsseldorf. Induction into the Plastics Hall of Fame is a recognition of both living and deceased personalities who have made major contributions to influencing and driving the plastics industry.

Commenting on this Maureen Steinwall, President Hall of Fame, says: “K in Düsseldorf offers the ideal platform to further promote the internationalization of the Plastics Hall of Fame and to honor individuals from all over the world who have made a special contribution to the international success of the plastics industry.”

The Plastics Hall of Fame was brought to life by the magazine Modern Plastics in cooperation with the Society of the Plastics Industry (SPI) in 1972. At the beginning, only important individuals from America were recognised in the Plastics Hall of Fame. With the increasing globalisation of the plastics industry, the need to also acknowledge the global accomplishments and innovations in this area

was recognised. This is why in 2004 the Plastics Hall of Fame started accepting international nominations. This step made it possible to recognise outstanding achievements and pioneering developments by experts from all over the world and stress the global importance of the plastics industry. The Plastics Hall of Fame currently has 235 members from 10 countries.

“We are delighted that the Plastics Hall of Fame has chosen K as the venue for its first gala outside the USA. This means there will be another glamorous highlight on the eve of K 2025,” says Thomas Franken, Director K at Messe Düsseldorf.

Every 18 months the newly elected members are honoured as part of a ceremony. The board of the Plastics Hall of Fame Inc. acts as a screening committee for the nominations, which are then checked and voted upon by the current members.

Nominations for the “Plastics Hall of Fame Class of 2025” are now open until late February 2025.

<https://plasticshof.org/membership/nominations/>  
[www.k-online.com](http://www.k-online.com)



## New Website Launched

■ Guill Tool & Engineering, world leader in extrusion tooling design and manufacturing, has unveiled a new website.

The new site offers a detailed look at the company’s entire product line, which offers a wide-range of standard and custom designed extrusion tooling, including cross-heads, in-line heads, rotary heads and extrusion tips & dies. Highlight among the new products is the in-line Spiderless Pipe Die, unique in the world market currently for its design efficiency and process performance on small to medium sized plastic pipe.

The site includes a full listing of all products and specifications with calculation tools to compute annual cost of lengthy concentricity adjustments and crosshead replacement analysis, plus calculators to compute draw-down, feet per minute and pounds per hour, making extrusion production scheduling and estimating far

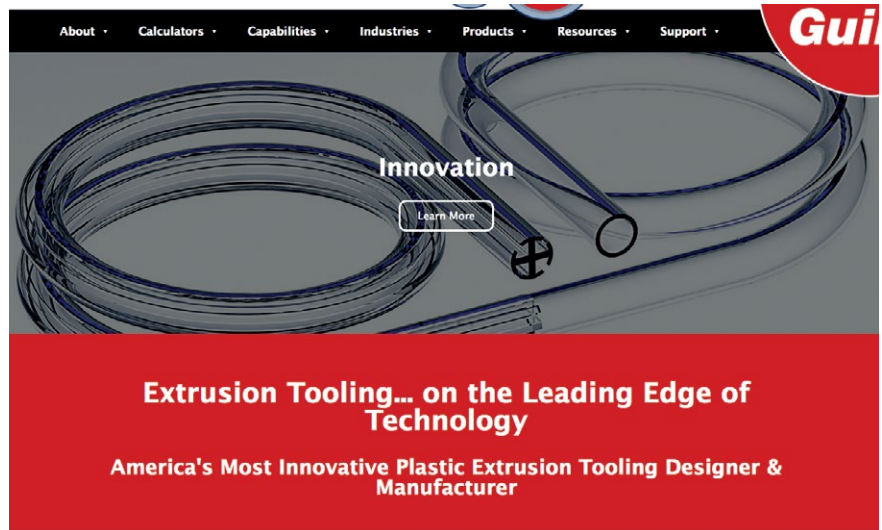

more accurate and efficient. The website also includes charts and tables with detailed data and a full library of downloadable literature organized by industry and tool type. Guill markets its equipment worldwide and is currently seeking new representatives in select countries.

The Guill website is mobile phone friendly and offers the convenience of allowing users to request a quote online.

**Guill Tool & Engineering**  
 West Warwick, Rhode Island (USA)  
[www.guill.com](http://www.guill.com)

## New Sales Office Opened in Singapore

■ BUSS announced its expansion in Southeast Asia. The opening of a new sales office in Singapore is setting another milestone in its international expansion.

With the support of the BUSS locations in China and Switzerland, Sien Kiong Lim will be the new sales manager for the Southeast Asia region from Singapore. Lim has many years of experience in the industry and is very familiar with the market requirements of his customers.

His focus will be on expanding existing customer relationships in Thailand, Indonesia, Malaysia, Singapore and Taiwan, as well as building new business relationships in countries without BUSS representation, such as Vietnam, Australia and the Philippines.

Thanks to his excellent technical background, Lim will be able to make an important contribution to promoting innovative BUSS compounding technology in the Southeast Asian market by providing technical advice and local support.

With the opening of the sales office in Singapore, BUSS is now even closer to its customers and can provide them with even better support. Mr Lim can rely on close cooperation with the BUSS location in Shanghai, China. This will make technical support in the region



*Sien Kiong Lim*

even quicker and easier, whether through the supply of spare parts or the involvement of service experts.

**BUSS**  
[www.busscorp.com](http://www.busscorp.com)

## Personalia

■ As of July 1, Marcel Perrevort has been appointed Chief Sales Officer (CSO) of the Reifenhäuser Group. He succeeds Ulrich Reifenhäuser, who had been in this position for more than 25 years. With this decision, the family-owned machinery and plant manufacturer is consistently continuing the already initiated generational transition in its management structure.

"I am very much looking forward to my new role as CSO and the associated task of strengthening our leading position in the market. One focus will certainly be the further expansion of our international sales and service units, which will enable us to become even more customer-centric in the market," says Perrevort.

Perrevort has held various sales and management positions within the Reifenhäuser Group for over ten years – most recently as Manag-

Marcel Perrevort  
(Pictures: Reifenhäuser)



ing Director of Reifenhäuser Blown Film. In his new role as CSO, he is primarily responsible for the Group's sales and service strategy and its alignment with the activities of the business units.

Ulrich Reifenhäuser says: "I have been working with Marcel Perrevort for many years now. He knows our business like the back of his hand. Knowing that I am passing the position on to a competent person makes it very easy for me."

Ulrich Reifenhäuser will continue his work in associations and committees within the plastics industry and will remain at the disposal of the Reifenhäuser Group as a representative and consultant with adjusted work hours.

Also with effect from July 1, Eugen Friedel is leading the business of Reifenhäuser Blown Film as the new part of the dual management team alongside Dr. Andreas Neuss. Friedel succeeds Marcel Perrevort, who has moved to the Reifen-

Eugen Friedel (left) is leading the business of Reifenhäuser Blown Film as the new part of the dual management team alongside Dr. Andreas Neuss (right)

häuser Group holding company as Chief Sales Officer.

Friedel has held various sales positions at Reifenhäuser Blown Film for over 25 years – most recently as Sales Director. In addition to focusing on sales, he is also responsible for product management and purchasing within the dual management team.

"Thanks to his many years in sales, Eugen Friedel knows the challenges and expectations of our customers very well. He therefore has the best qualifications for the new management position," says Bernd Reifenhäuser, CEO of the Reifenhäuser Group.

Reifenhäuser Gruppe  
www.reifenhäuser.com

## Organizational Integration after more than 35 Years of Successful Sales and Service Partnership

■ Sesotec, based in Lower Bavaria, and Mobergs Produktkontroll AB in Sweden announce the next stage of their mutual commitment after more than 35 years of successful sales and service partner-

ship: Mobergs will intensify its central role for sustainable growth in the Scandinavian region as an official "Member of Sesotec Group" and subsidiary of Sesotec GmbH.

Existing and future customers will benefit not only from the synergies between the two companies in terms of technical and regional expertise in the field of Sesotec's own systems for foreign body de-

tection and material sorting, but in particular from the shared experience and philosophy of maximum customer satisfaction and the best service within the food, plastics and recycling industries.

“Our shared values, which have grown from our long history together, were the basis on both sides for this official step and our commitment to each other,” explains Joachim Schulz, CEO of Sesotec GmbH. “Being a reliable partner has always been an important principle for Sesotec. The long-standing cooperation with Mobergs is an outstanding example of such a partnership in action. We are therefore very pleased to start an even closer cooperation with Fredrik Moberg and his team and to welcome them as a permanent member of the Sesotec Group. This commitment to Sesotec makes us and our employees very proud.”

Fredrik Moberg, founder and original owner of Mobergs Produktkontroll AB, will continue to play a leading role in the regional development of the company as Managing Director and will lead the experienced team into a strategically secure future in the Scandinavian and in the future also in the Baltic countries.

Fredrik Moberg justifies his decision to integrate into the Sesotec Group with the sustainable future viability of Mobergs Produktkon-



Fredrik Moberg (left) and Joachim Schulz are delighted with the new member of the Sesotec Group

troll AB: “During more than 35 years of partnership, Sesotec and Mobergs have always developed in the same direction. Our internal and external relationships are characterized by shared values and goals and mutual appreciation, which is why we have always felt like partners at eye level. With the process and resource-related integration, we are now optimally positioned for the future in order to meet the dynamically growing customer and market requirements even better. We benefit from Sesotec's technical expertise and are

able to meet the key challenges of the future with confidence and even benefit from megatrends such as artificial intelligence in relation to service and predictive maintenance. The decision was therefore not only logical, but also important for the future development of Mobergs.”

The first major joint appearance of the two companies will take place at Scanpack in Gothenburg in October 2024.

Sesotec GmbH  
[www.sesotec.com](http://www.sesotec.com)

## High-Performance Screw Barrel and Feed Bush Replacements:

Ad Conextru (1/3 horizontal)



**BARRIER SCREW DESIGN & STRAIGHT GROOVED FEEDBUSH**  
 for best melt homogeneity based on CONEXTRU technology



**COMPATIBLE MADE FOR MAJOR BRANDS**  
 like Battenfeld-Cincinnati, Reifenhäuser, Krauss Maffei, & others



**QUICK DELIVERY – REASONABLE PRICES**  
 in standard or wear-resistant execution



[www.conextru.eu](http://www.conextru.eu)



## Food Safety Management Certified

■ To further strengthen the trust of business partners and customers in the global food packaging industry, the safety management of Tosaf's production facilities for white and additive masterbatches has recently been certified to ISO 22000. This globally recognised key standard comprises strict specifications including production and processing, transport, storage and labelling of products used in the food industry. The company had already been certified in accordance with the international quality standards ISO 9001, ISO 14001 and ISO 45001.

As a company that has always focussed on the needs of its end customers, Tosaf has decided to take this voluntary step. With this current certification, which includes continuous monitoring and documentation as well as preventive measures to minimise risks, the masterbatch manufacturer is now one of the few of its kind in the world to make this additional contribution to health protection along the entire food chain.

As part of the requirements of ISO 22000, Tosaf utilises the most advanced computer technologies and control systems to ensure maximum quality and safety as well as complete traceability of its products. The numerous safety measures range from the particularly critical selection and regularly review of suppliers as well as strict incoming raw materials inspections up to product release. They also include particularly careful selection of per-



sonnel and strict access controls to the production facilities.

Tosaf provides detailed documentation on the substances contained in the white and additive masterbatches it delivers. It declares conformity with the relevant regulations and helps its customers, mainly manufacturers of food packaging, including films, injection and blow-moulded parts such as yoghurt pots, bottles, etc., to document their own company's fulfilment of the strict regulations.

As Dina Khomchuk, Q&A Manager for Tosaf's Additives Business Unit explains: "Tosaf places great importance on supplying the food industry with high-quality raw materials that meet the strictest requirements. As part of the new ISO 22000 certification including ISO 22002 Part 4, which is specifically tailored to food packaging, we have comprehensively adapted our processes to this area of application and optimised them even further. We have developed a

*The food safety management of Tosaf's masterbatch production facilities is now ISO 22000 certified (© Tosaf)*

multi-year plan that includes measurable goals in the areas of quality, food safety, and environmental quality. We allocate resources and train the entire organization in food safety. On this expanded basis, Tosaf is looking forward to growing in the market for masterbatches for food packaging."

The majority of Tosaf's additives and white masterbatches are intended for the food packaging sector, where they enhance the performance and safety of the materials used. In addition to extrusion, including the production of multilayer and BOPP films as well as extrusion coating, injection moulding and blow moulding are typical processing methods for these products.

Tosaf Compounds Ltd.  
[www.tosaf.com](http://www.tosaf.com)

## Sustainable Plastics Solutions

■ Plastics processor Ensinger has committed itself to the goal of a sustainable future. The family business's net-zero climate goal was recently confirmed by the Science Based Targets initiative (SBTi). In order to make an additional contribution to reducing greenhouse gas emissions, Ensinger has now introduced sustainable plastic solutions consisting of bio-based and reprocessed stock shapes. The company's business partners are also involved in the measures for reusing plastics.

With the expansion of its stock shapes portfolio, Ensinger is presenting two innovative product lines that enable a significant reduction of the CO<sub>2</sub> footprint:

The new bio-based plastics from Ensinger are produced from basic materials generated by the wood-processing industry, along with other organic waste. The manufacturing method for the plastic plates, rods and tubes is similar to conventional production processes, meaning that similar property profiles are guaranteed. Apart from minimal color deviations, the

bioplastic products from Ensinger have comparable specifications.

The other new product line, namely reprocessed plastics, is produced from returned materials and production waste using mechanical treatment processes, thereby giving a second life to fossil fuel-based materials. Although the material properties of these products may deviate slightly from those of conventional materials, this is significantly outweighed by the environment benefits. The reprocessed stock shapes are available in the form of rods, tubes and plates.

It is not only about innovative material solutions: energy projects, material savings and recycling are making crucial contributions to reducing greenhouse gas emissions. Ensinger's sustainability initiative consists of four building blocks.

1. Prepare for Tomorrow: Under this guiding principle, Ensinger is implementing a variety of environmental projects and energy-saving measures which are helping to reduce greenhouse gas emissions throughout the supply chain and get close to the net zero target called for by the Paris Agreement.

2. Reduce for Tomorrow: An important step on the path towards sustainability is a reduction of the CO<sub>2</sub> footprint at the start of the production chain. Ensinger works closely with its customers in order to offer stock shape blanks in optimum formats or supply customized finished parts and thereby minimize waste. This approach not only reduces consumption of materials but also the greenhouse gas emissions generated through transport.

3. Recycle for Tomorrow: Recycling makes a key contribution to conserving raw material resources and reducing CO<sub>2</sub> emissions. Ensinger has many years of experience with a diverse range of polymer processing methods and is supporting the transition to the circular economy through the systematic recycling of engineer-



Ensinger's aim is to promote the sustainable use of plastics

ing and high-performance plastics. One of Ensinger's most important product lines is insulating profiles, which consist of 100% unmixed recycled polyamide.

4. Reuse for Tomorrow: Repeated use of raw materials is a long-term goal of the sustainability initiative. With the current expansion of its portfolio to include bio-based and reprocessed stock shapes, Ensinger is responding to a growing demand in this sector.

Ensinger's new biobased stock shapes, produced with mass balanced approach manufactured resins, include TECAFORM AH EF natural (POM-C), along with TECAFORM AD EF natural (POM-H), TECAPEI EF natural (PEI) and TECAST T EF natural (PA6 C). The stock shapes product family of reprocessed polymers starts with TECAPEEK RP natural (PEEK) and will be continuously amended in the future.

Ensinger Group  
[ensingerplastics.com/en/sustainability/product-solutions](https://ensingerplastics.com/en/sustainability/product-solutions)



**DISCOVER OUR  
TR3515PE**



**Automatic coiler** consisting of **one reel**, with **one or two strapping units**, **anti-ovalisation haul-off**, automatic unloading, ideal for coiling **smooth PE pipes** or for **district heating pipes** from diameter 75 to 160 mm, with a reel width up to 1500 mm and coil weight up to 1.5 ton.







## New Compact Design FFU Universal Gate Valve

■ Coperion has developed a new discharge gate valve for controlled bulk material flow from storage bins and hoppers to downstream process steps. This valve is suited for a variety of applications in the chemical and plastics industries with its impressively compact yet very robust construction. One particular feature of this new discharge valve is that it closes securely and reliably while material is flowing, but usually also when the product column is stationary, making this a perfectly suited gate valve for demanding applications. This new valve that is well thought out in design and construction secures operators a singularly reliable technology solution and makes installation and maintenance simple.

Coperion manufactures this discharge valve using a precision cast-

ing process, enabling its compact and lightweight design. Its intelligent geometry, select guide elements and the form of the seal ensure that the FFU universal gate valve can be used for a wide variety of applications with the most diverse demands – even in combustible areas (ATEX). This new geometry is what allows the gate valve to be used in the usual way even when the bulk material is stationary and best of all, its high-quality, robust construction ensures dependable operation over time. Various models with manual or pneumatic drive are available in sizes DN 150 to 400 (6 to 16 inches) and can be implemented in a variety of customer-specific options.

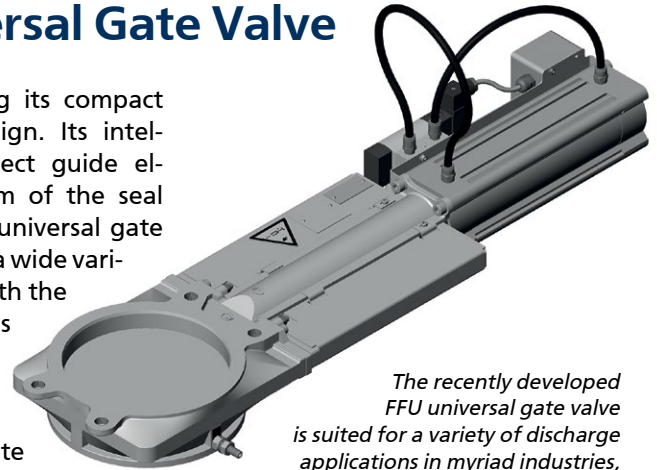

*The recently developed FFU universal gate valve is suited for a variety of discharge applications in myriad industries, boasting a compact yet very robust construction as well as the ability to close when product is stationary (Photo: Coperion, Weingarten/Germany)*

Coperion GmbH

► [www.coperion.com](http://www.coperion.com)

## Lumps and Neckdowns have No Place in the Filament

■ PMH based in Königswinter, Germany, knows from many years of experience how important the production of high-quality filaments is for the 3D printing industry. For more than 30 years, the company has been developing customized extrusion lines and equipping its lines with state-of-the-art measuring and control technology from SIKORA to ensure the highest product quality for its customers.

Especially in the production of filaments for 3D printing in medical technology, quality assurance is increasingly becoming the focus of manufacturers. Flawless filaments

ensure an optimal material flow during printing. This prevents feeding errors, clogging of the extruder and damage to the print head and nozzle.

In addition to devices for diameter measurement, PMH's extrusion lines also use LASER LUMP 2000 systems for quality control. The LASER LUMP 2000 is a real all-rounder: it precisely measures the diameter using laser technology and simultaneously detects lumps and neckdowns on the filament surface. SIKORA technol-

ogy is thus doubly efficient in ensuring that the filament produced meets the highest quality standards and reliability requirements.

SIKORA AG

► [www.sikora.net](http://www.sikora.net)

pmh gmbh

► [www.pmh-extruder.de](http://www.pmh-extruder.de)

*PMH uses the LASER LUMP 2000 from SIKORA for diameter measurement and detection of lumps and neckdowns*



*From left: Michael Kinnart, Technical Manager at PMH GmbH, with Aguinaldo Ramalho, Head of Sales - Wire & Cable, at the filament line with the integrated diameter measuring head and lump detector LASER LUMP 2000 from SIKORA*



# In-line Quality Control for Plastic Recyclate

■ The RecyQuant research project makes it possible to monitor and maintain tolerable levels of foreign materials in the recyclate directly in the process. The joint project between ColVisTec AG and the SKZ Plastics Center successfully implemented the detection of foreign polymers and the direct readjustment of the dosing scales. The basis for this was the modeling of the photometric data of the plastic melt.

A major challenge when using recyclates in the extruder process is the fluctuations in quality. In addition to general impurities, post-consumer recyclates in particular contain foreign polymers. However, excessive levels of foreign polymers in the base polymer lead to inferior product quality.

In a joint project, the SKZ Plastics Center and ColVisTec took on the challenge of measuring and automatically correcting the foreign polymer content during the ongoing process in 2022. In the event of a deviation from defined tolerance ranges, the process sequences were to be automatically adjusted by coupling with the extruder's system technology. The aim of the two-year research project was to realize a new application of CVT technology, which is to be marketed as a system combining hardware and software.

The research team was very satisfied with the results once all the tests had been completed. The main objectives were achieved and the concept was proven on a demonstrator. First of all, a chemometric model for predicting the foreign polymer content (polyethylene content between 0 and 10% by weight) in the base polymer (polypropylene) for virgin and recycled material was created in the project. A reduced wavelength range in the near-infrared could be determined for a high prediction accuracy. The suitability of the photometric approach



Test setup at the SKZ (Photo: Kilian Dietl, SKZ)

was demonstrated using a spectrometer and modeling. In addition, both a cost-effective broadband probe for the UV-VIS-NIR spectral range and a flexible software package for control were developed. The latter enables the dosing scale to be controlled when the threshold value of the foreign polymer quantity is exceeded.

“The decisive factor is that carrying out tests using demonstrators on realistically colored recycled material was able to prove that the measuring system is sufficiently sensitive even for weakly reflective material,” explains Cosima Güttler, Scientist Spectroscopy at SKZ. The solution developed enables significantly improved quality control when using recycled material and therefore makes a valuable contribution to both product quality and the circular economy.

SKZ Plastics Center  
Cosima Güttler, c.guettler@skz.de  
➔ [www.skz.de](http://www.skz.de)

## Energy Efficient - Easy Maintenance - Excellent Flakes Modular system solutions for automated PET washing lines



## Series of High-Performance Blown Film Line Launched

■ Rajoo Engineers hosted an exclusive, invite-only event on the 4th and 5th of July, 2024, bringing together the processors, innovators & leaders of the flexible packaging industry. This prestigious event was held in Rajkot, India and featured a blend of cultural and industry-focused activities, catering to a global audience.

The event began with a heartfelt welcome address, setting the tone for an evening of networking and collaboration. Guests experienced a cultural performance, highlighting the richness of Indian heritage and traditions, fostering a deeper appreciation and understanding amongst the attendees.

The highlight of the evening was the panel discussion titled "Drishtikon", focusing on the supply chain of the flexible packaging industry. The session was moderated by Shri Sunil Jain, Executive Director & President of Rajoo Engineers Ltd. Panelists were: Shri Unmesh Nayak, COO of Reliance Industries Ltd, Shri Chandrakant Virani, Chairman of Balaji Wafers Pvt. Ltd. Shri Rajesh Doshi, Chairman of Rajoo Engineers Ltd., Shri Pranav Bhalara, Director of Balaji Multiflex Pvt. Ltd., Shri Gabriele Caccia, Group President & CEO of Syncro SRL, and Shri Vipin Chaudhry, Director of Hi-Tech Inks Pvt. Ltd. The panelists shared their insights and perspectives on the current trends and future directions of the flexible packaging industry, providing valuable information and engaging discussions among the attendees.

This event served as a networking prelude, bringing together key

stakeholders from the entire value chain of the flexible packaging industry. It set the stage for meaningful interactions and paved the way for future collaborations.

The second day of the event marked as an exclusive Product Premiere at Balaji Multiflex Pvt. Ltd., heralding the grand debut of the PROEX Series, the latest in high-performance blown film extrusion technology.

As the curtains parted, the PROEX series was unveiled, captivating the audience with its remarkable performance. The line in commercial production highlighted its capability to produce film at 900 kg/hr, 22 micron thickness and 2800 mm lay-flat width. The RELEX 4.0 extruders, established for their low shear heat design, showcased optimal energy efficiency and high yield. CSD 4.0 die, the heart of the line, capable of delivering film thickness from 20 to 200 microns across a wide 2800 mm lay flat width and low gage variation, the system achieved unprecedented line speeds of 150 m/min.

Shri Pranav Bhalara, Director of Balaji Multiflex Pvt. Ltd., expressed

*PROEX – New Series of High Performance Blown Film Extrusion Line*



PROEX - New Series of High Performance Blown Film Extrusion Line



„Drishtikon“ – The Panel Discussion by industry stalwarts

his pride in supporting the 'Make in India' initiative and the 'Vocal for Local' movement, stating, "I am delighted with the PROEX series. This high-performance blown film line exemplifies that we can achieve world-class quality through Indian ingenuity and innovation."

Rajoo Engineers Ltd. is a pioneer in the plastics industry, committed not only to technological innovation but also for customer's advantage. Khushboo Chandrakant Doshi, Managing Director, Rajoo Engineers Limited: "Spiritual professionalism inspires us to embrace integrity, respect, and holistic growth in our innovative pursuits, ensuring that our efforts benefit not only technological advancement but also the greater good of our customers, community, and environment. Guided by a higher purpose, we align our values with our mission, creating an impact that resonates far beyond our walls."

Rajoo Engineers Limited

➔ [www.rajoo.com](http://www.rajoo.com)



## Comprehensive Expertise United Under One Roof

■ With effect from 1 August 2024, the former Schenck Process Food and Performance Materials (FPM) group of companies have officially changed their name to Coperion. The transition follows the September 2023 acquisition of the companies by Hillenbrand, the parent company of Coperion.

The integrated Coperion companies combine the strengths of multiple process industry leaders under a single brand, offering manufacturers a broader portfolio of solutions,

technologies and services across the food, health and nutrition markets, such as baking, confectionery, pet food, pharmaceuticals and cosmetics, as well as the polymers/performance materials industries such as plastics, plastics recycling, chemical, battery and minerals.

Coperion brings flagship brands together under one roof, including those that were formally from Schenck Process (FPM) - Raymond Bartlett Snow, Stock, Baker Perkins, Kemutec, and Mucon. This allows

Coperion to offer solutions to customers in a more streamlined way – with an even deeper team of process experts and collaborative problem-solvers. Customers will continue to receive hands-on service and support, including access to test and innovation centers around the world.

Along with the name change, the website has moved to [coperion.com/fpm](http://coperion.com/fpm)

**Coperion**  
 [www.coperion.com](http://www.coperion.com)



**Zumbach**  
 SWISS PRIME MEASURING SINCE 1957

**min**  
**2**  
 Min. object diameter (mm)

**300**  
 Line speed (m/min)

**max**  
**108**  
 Max. object diameter (mm)

**140'000**  
 Scan rate (scans/s)



### SIMAC®

## Cable, Pipe & Hose Surface Quality Inspection System

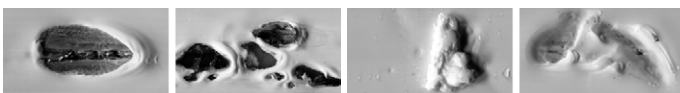

#### Benefits:

- ✓ Accurate & continuous detection of the tiniest surface anomalies and material defects
- ✓ Advanced defect detection algorithms detect all surface variations
- ✓ Image processing based technology with a scan rate of 140,000 scans per second
- ✓ Offers continuous in-line surface inspection with a line speed up to 300m/min
- ✓ Optical system using four cameras ensure 100% coverage with overlapping imaging zones

## Partnership with AI Start-up

■ Meraxis, a worldwide leading plastics distributor, and the AI deep-tech start-up POLYMERIZE have forged a strategic partnership. POLYMERIZE is a developer and provider of a materials informatics platform, which is specifically tailored to the research and development needs in the polymer industry. POLYMERIZE's Software-as-a-Service platform allows converters, producers, and compounders to optimize their materials development and launch new – and more sustainable – products more quickly. This partnership aims to expand their range of services in the European market. Meraxis is also a shareholder of the Singapore-based start-up.

POLYMERIZE's platform assists research teams in handling data more effectively and developing new material formulations more efficiently. This in turn drives down development costs for polymer processing companies and expedites the "time to market" for new products. Dr. Stefan Girschik, CEO of Meraxis, highlights: "The partnership with POLYMERIZE strengthens our role as a one-stop shop and driver of digital transformation in the polymer industry. We are firmly convinced that digital solutions such as this one hold the key to increased competitiveness and sustainability. The AI-supported POLYMERIZE software allows polymer converters to considerably shorten their innovation cycles and accelerate the development of sustainable products. We have had very positive results when using the software ourselves."

POLYMERIZE's deep-tech solution simplifies the uploading and management of data from test series and analyzes it by means of artificial intelligence, automat-

*Kunal Sandeep (left) and Dr Abhijit Salvekar (right), founder of Polymerize (Source: Polymerize)*



*Dr Stefan Girschik, CEO Meraxis (Source: Meraxis)*

ed workflows, and statistical evaluations. On this basis, the platform optimizes the approach to new material experiments and precisely predicts the test results. The software utilizes AI to propose new formulations or alternative ingredients to produce the required properties, such as a specific elasticity, hardness, or viscosity. In addition, POLYMERIZE minimizes the ecological footprint by helping researchers and formulation developers reduce resource consumption and create formulations with sustainable materials more quickly. Each user's data is stored in an isolated manner. POLYMERIZE deploys state-of-the-art security measures that are audited at regular intervals. This ensures compliance with the ISO 27001 and SOC<sub>2</sub> TYPE II data protection standards and the GDPR conformity.

Meraxis harnesses this strategic partnership to support its customers and suppliers in systematically implementing and using POLYMERIZE solutions to advance their sustainability initiatives. Kunal Sandeep, Co-Founder and CEO of POLYMERIZE, comments on the partnership: "With Meraxis as our partner, we now have access to European polymer converters and producers. This helps us to expand our position in this key market and further establish our platform in Europe." Co-Founder and CTO Dr. Abhijit Salvekar adds: "Working in partnership with Meraxis, we are driving digital solutions in the polymer industry to improve efficiency and environmental sustainability in the sector." In 2020, the two founded POLYMERIZE together. Sandeep is an accomplished founder in the realm of software-as-a-service. Salvekar has a long-standing practical research & development experience in the polymers industry.

Meraxis Group  
[www.Meraxis-group.com](http://www.Meraxis-group.com)

POLYMERIZE  
<http://polymerize.io>

# Production Reliability Maximized by Uninterruptible Power Supply for Printers

■ Even after power outages in production, LEIBINGER's new IQJET industrial printers are immediately ready to resume operation. Controlled shutdown with a closed ink circuit is assured by their innovative uninterruptible power supply function and automatic nozzle sealing technology. There is therefore no need to clean the printers before restarting them, avoiding the need for additional downtime.

Right around the globe, power outages are a fairly commonplace occurrence. Asia, Africa and South America are affected, and so is Europe. For companies, this signifies unscheduled downtime, production delays and additional costs. Once a power outage has been resolved, production then urgently needs to get back up to speed. However, conventional industrial printers that print codes or serial numbers on products and packaging commonly experience start-up problems after power outages. The devices process inks that dry very fast indeed and, when a power outage occurs, they shut down spontaneously. The ink then dries up within a very short time, contaminating the print head and clogging the lines. Restarting those printers then usually first involves a time-consuming manual cleaning process.

To avoid the kind of complications described above, the IQJET from LEIBINGER features an integrated energy storage system for an uninterruptible power supply (UPS). In the event of a power failure, an IQJET printer powers itself down fully and its print nozzle automatically gets sealed airtight, ensuring that the ink does not dry out. This also protects the print head from getting contaminated. Even after extended periods of downtime, the IQJET is immediately ready for use again and does not need to be cleaned. The UPS can also bridge relatively short power interruptions. This prevents malfunctions and fluctuations in print quality. In contrast to conventional printers, there are no breakdowns or problems with the ink when operator errors occur.

Paul Leibinger GmbH & Co. KG  
[www.leibinger-group.com](http://www.leibinger-group.com)



The uninterruptible power supply on the IQJET enables these printers to power down in a controlled manner, and to start up again immediately, as soon as power is restored to the production system (Source: Paul Leibinger GmbH & Co. KG)

hoch5.com

## CCA

The Original

### Quality is our Priority

Backed by 30 years of experience, CCA develops calibration sleeves for plastic pipe extrusion:

- from Ø 12 mm up to Ø 2.400 mm pipe outside diameter
- precisely matched to the production requirements of our international customers

Rely on quality „Made in Germany“.



[www.ccagmbh.de](http://www.ccagmbh.de)

## New HiQuad® Neo Mass Spectrometer Introduced

■ With its new HiQuad Neo mass spectrometer, Pfeiffer Vacuum combines powerful performance with flexibility and user-friendly operation. This mass spectrometer achieves an exceptionally high measuring speed of up to 125  $\mu\text{s}/\text{u}$ . It is distinguished by its outstanding sensitivity and a wide dynamic range. Depending on the application different, mass ranges, rod diameters, ion sources, detectors, interfaces and cable lengths are available for selection. Its properties predestine the HiQuad Neo most particularly for applications in research and development and make it ideal for integrating into analytical systems as well as for cleanliness verification for EUV-lithography.

Previous-generation devices can be upgraded to match the latest HiQuad Neo technology. It is also possible to re-use existing components, such as the analyzer. This minimizes both expense and waste.

The mass spectrometer is easy to operate with the PV MassSpec software. This provides a

clear, user-friendly platform for recording and presenting measured data as well as parameter settings. The integrated sequencer enables easy automated programming of entire measuring procedures. One click is all you need to perform leak detection and vacuum diagnosis. The software also permits automated calibration and tuning. Defining measurement recipes is easy, and it is possible to link the

mass spectrometer data to external signals. Alternatively, direct communication via the ethernet interface (via OPC-UA) is possible. These features provide an efficient, user-friendly solution for a wide range of applications.

Pfeiffer Vacuum GmbH

► [www.pfeiffer-vacuum.com](http://www.pfeiffer-vacuum.com)



## Biopolymers Portfolio Expanded

■ BASF is now offering the packaging industry a way to increase the use of renewable feedstocks: It is expanding its portfolio of certified compostable biopolymers to include a biomass-balanced (BMB) ecoflex®, a polybutylene adipate terephthalate (PBAT) that is frequently used in the compounding of biopolymers. For the new ecoflex® F Blend C1200 BMB, the fossil raw materials that are usually used in the production process are replaced with renewable feedstock at the beginning of the value chain. The renewable feedstock comes from waste and residual biomass and is attributed to the ecoflex® grade via a mass balance approach which is certified according to REDcert2 and ISCC PLUS. The biomass-balanced ecoflex® not only contributes to reducing the use of fossil resources, but it also offers a 60% lower Product Carbon Footprint (PCF) than the standard ecoflex® F Blend C1200.

Certified compostable products based on PBAT compounds help create a circular economy by supporting the collection and recycling of organic waste. However, in the production of PBAT, it is not yet possible to fully avoid the usage of fossil resources. With ecoflex® BMB,

BASF closes this gap and offers a solution that is organically recyclable at the end of life: In addition, its fossil feedstock is completely replaced with renewable raw materials at the very beginning of the production process. BASF is thus taking another step towards closing the biological loop of circular economy.

ecoflex® BMB enables customers in the packaging industry to contribute to the reduction of fossil resource consumption and differentiate their products without compromising on performance and quality, or the need for extra investment into new processing lines: The BASF PBAT is identical to the conventional grade in properties, quality, and certification. As a result, customers do not need to re-qualify their applications made of ecoflex® BMB, reformulate the compounds or adapt their existing manufacturing processes: They can rely on the same performance to which they are accustomed and benefit from a drop-in solution.

BASF Performance Materials

[www.ecoflex.basf.com](http://www.ecoflex.basf.com)

► [www.basf.com/massbalance](http://www.basf.com/massbalance)

# Blow Molding Dies

■ Guill Tool offers its Series 1000. This series of blow molding extrusion dies, features a core diameter between 8.5" (219.5 mm) to 10" (254.0 mm). Model 1025 uses material blends which are ideal for medical, automotive and specialty packaging.

Series 1000

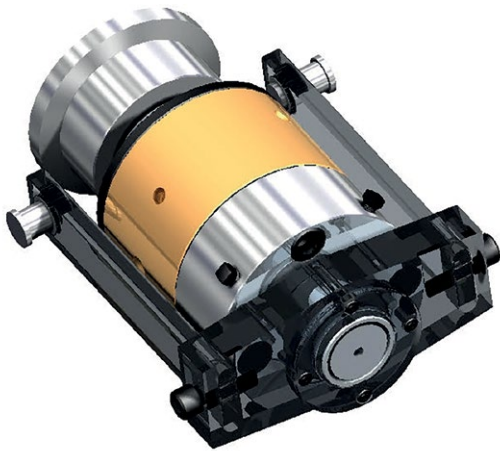

Blow Mold

Series 1000 is available as single layer, co-extrusion or triple extrusion. It adapts to existing extruder layout and in most cases, accepts existing tooling. Features include fixed center or adjustable, built-in cartridge heaters, low inventory, expandable to multi-layer, heated core pin,

one-piece body/flow diverter and split feed balanced flow.

Most products should be run fixed. Users need to change only one component to become fully adjustable. The cartridge heaters offer even heat for better flow and ensure there aren't any cold spots. Low inventory produces no burning or stagnation, resulting in quick color change. Since it's expandable to multi-layer, the crossheads run a variety of products. Benefits of the heated core pin and one-piece body/flow diverter are better temperature control and easy cleaning/quick change over, respectively. Lastly, the split feed balanced flow achieves concentric walls at all speeds.

**Guill Tool & Engineering**  
Tom Baldock,  
Sales Manager, Extrusion  
tbaldock@guill.com

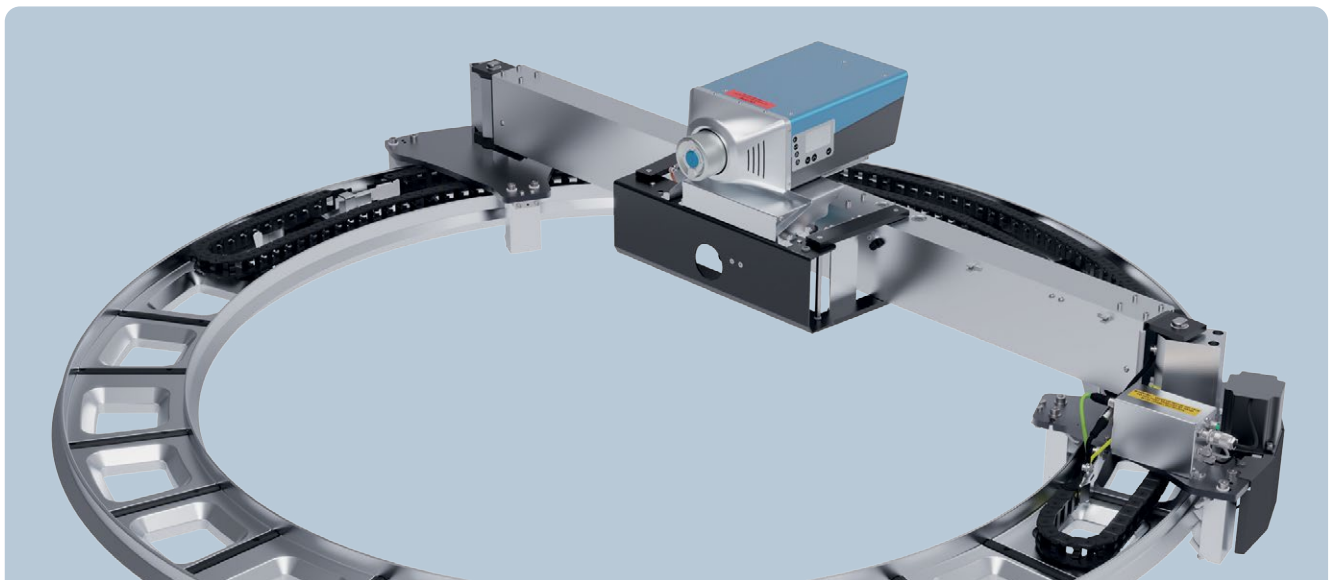

## KNC-401 Rotomat KT 3G

It's not just an upgrade, but a whole new generation



**KÜNDIG CONTROL SYSTEMS**  
The Gauge Manufacturer for Film Extrusion SWISS MADE

## Market Study – Plastic Pipes

■ Centrifugally cast, wound, or extruded: glass fiber-reinforced plastic pipes are particularly robust, heat-resistant, and durable. Both glass fibers and synthetic resins can be processed directly on site and cured with hot water or UV light, in the event of pipe damage, for example. The latest, seventh edition of the Ceresana report on the European market for plastic pipes includes GRP pipes as a separate product category for the first time. Pipes made of fiber-reinforced composites, usually mixtures of glass fibers and thermosetting polyester or epoxy resins, are currently the market segment with the most dynamic growth. However, their costs and requirements are higher than those of pipes made of polyvinyl chloride (PVC), polyethylene, polypropylene, or other thermoplastic materials: To date, GRP pipes only make up a relatively small proportion of the approximately 5 million tonnes of plastic pipes sold in Europe each year.

The Study in brief:

**Chapter 1** analyzes the entire European market for plastic pipes –

### Market Study: Plastic Pipes



Ceresana  
Market Research Since 2002

and provides forecasts up to the year 2033. Key figures such as revenues (in US dollars and euros) as well as production and demand (in tonnes) are given for each world region. Sales are also broken down into application areas. Demand is broken down in detail for the various application areas, construction segments, and plastic types (glass fiber reinforced plastics are covered separately). The production volume is broken down by type of plastic

(GRP not shown separately here). **Chapter 2** provides specific market data on plastic pipes for 24 European countries: Revenues, imports and exports, production and demand volumes, broken down as described for chapter 1. The following individual sub-segments are included:

**Application Areas:** Sewage disposal, potable water supply, cable protection, gas pipes, agriculture, industry, other applications.

**Types of Plastics:** Polyethylene (PE), Polypropylene (PP), Polyvinyl chloride (PVC), Glass fiber reinforced plastics (GRP), other types of plastics.

**Construction Segments:** New construction, renovation, residential construction, commercial construction and infrastructure.

**Chapter 3** provides company profiles of the largest manufacturers of plastic pipes in Europe – clearly arranged according to contact details, revenues, profit, product range, production sites, and profile summary. In-depth profiles of the 53 most important producers are given.

<https://ceresana.com/en/produkt/plastic-pipes-market-report-europe>

## Baby Bottles – Safe and Robust

■ Baby bottles of the baby feeding and nurturing products brand Thyseed are now made of BASF's high-performance thermoplastic Ultrason®. The bottles for babies and toddlers benefit from the BASF polyphenylsulfone (PPSU) Ultrason® P 3010 in several ways: It is approved for food contact and features excellent mechanical strength, chemical resistance as well as resistance to superheated steam at 134°C. These properties ensure that the baby bottles are safe to use, while being lightweight and shatter-proof. They easily withstand the high temperatures in dishwashers and microwave ovens and can thus be reused many times without losing their excellent mechanical properties or their optical appearance. Thyseed and BASF have also entered into a strategic



cooperation to explore the advantages of Ultrason® for other products of Thyseed in China and beyond.

"Thyseed has been committed to customizing the world's best products, with exquisite materials

and processes, innovative product design and services, to protect babies' entrance into the world," says Wang Hao, Brand Founder and CEO of Thyseed. "Through the use of BASF's high-performance PPSU, our products will set new safety

and quality standards in the global market. At the same time, it will also help Thyseed to further expand internationally and enhance our brand competitiveness. The cooperation with BASF is not limited to the supply of Ultrason® but involves further development to ensure that this high-performance material can be effectively applied to our products, thereby improving their overall quality and user experience." The strategic cooperation, which was

officially signed at a launch event in Shanghai on July 17, 2024, will include collaboration on technical innovations as well as exchanges on trends and sustainability topics like reusability and high health standards.

The transparent, lightly honey-colored Ultrason® P 3010 is a medium viscosity grade with superior toughness and stress crack resistance. It is well-suited for injection stretch blow molding, which is the most

widespread manufacturing process for baby bottles in Asia. The production advantages of Ultrason® P 3010: rapid cycle times and easy processing with suitably configured hot runner systems without scrap losses.

**BASF**  
[www.ultrason.basf.com/householdcatering](http://www.ultrason.basf.com/householdcatering)

**Thyseed**  
[www.thyseed.com](http://www.thyseed.com)

## Sustainability Report

■ Two years ago, a severe drought hit the Nelson Mandela Bay municipality on the southern coast of South Africa. Reservoirs were nearly empty, pushing the population of 1.3 million close to "day zero" when water stops flowing from the taps.

The region is home to an Orion facility that produces carbon black – an essential material for the country's tire industry. The crisis inspired Orion to find a solution that would help the municipality conserve its precious water supply.

Despite significant engineering challenges, Orion built a water treatment system at its facility. The technology recycles treated effluent water from a nearby municipal sewage plant so that the water can be used in Orion's production process.

"The potable water we once used to make our products is saved for the community," Orion CEO Corning Painter said. "The treated effluent water that once got pumped into the ocean is now repurposed for an industry that makes carbon black, which enables car tires to last longer and perform better. Recycling the water will also lead to a substantial cost savings."

The South Africa case study is featured in Orion's "Sustainability Report 2023," which the company released today with the theme: "Driving innovation, enabling the everyday." The report covers a variety of highlights, including:



- Achieving an EcoVadis Platinum Medal, positioning the company in the 99th percentile of companies evaluated.

- Opening a Battery Innovation Center to develop new products and formulations for lithium-ion batteries driving the shift to electrification.

- Investing €12.8 million – including €6.4 million in grant funding from the German government and European Union -- to further develop and demonstrate a climate-neutral process for producing carbon black from alternative carbon sources.

- Leading the carbon black industry in the number of production sites with ISCC (International Sustainability & Carbon Certification) PLUS certification.

- Reaching the goal of having 80% of employees receive 40 or more training hours – double the average training hours in 2022.

In the report, the company unveiled its water-recycling project in

South Africa. Orion is the only global company in the carbon black industry that has a site in Sub-Saharan Africa.

The project began in early 2023 and involved installing a 65-meter-long pipeline from the Orion site to the municipal water treatment plant. A horizontal-boring process was used to run the pipeline 5 meters under a road.

A 7-meter-deep sump had to be built for the system. This was a major excavation challenge because the sandy soil did not provide much solid ground. It was like digging a hole in a sand dune. But the team used sandbags to stabilize the ground and keep the hole from being filled with water.

Orion now has the capacity to recover 3 million liters a day from the municipal plant and treat the effluent water so that it meets the quality level for the site's production process.

**Orion S.A.**  
[orioncarbons.com](http://orioncarbons.com)

## Reusable PET Bottle for Cosmetic Products

■ zerooo stands for reusable packaging that fosters the circular economy in the cosmetics industry. The system offered by start-up SEA ME GmbH offers brand manufacturers safe, affordable and sustainable PET bottles, in addition to glass bottles, for the first time. Together with ten brand partners and packaging and recycling specialist ALPLA, the company has developed a fully recyclable solution. The reusable PET bottle, with a volume of 300 millilitres, is available in clear, milky white and brown versions. It is suitable for all caps and

*With ALPLA's support in the development of the bottle, SEA ME GmbH is producing the first reusable PET-system for cosmetic and care products in Germany and Austria (Copyright: SEA ME GmbH)*



can also be used as a shatterproof alternative for toiletries in the shower. Further formats are planned.

From September, the first manufacturers in Germany present cosmetics and care products in PET containers from the zerooo reusable system. Empties can be returned to the approximately one thousand collection points of zerooo retail partners for a deposit of €0.50.

As a globally active packaging manufacturer and recycling specialist, ALPLA is promoting closed 'bottle-to-bottle' cycles with its own plants. The company contributes its expertise as a system supplier and also supports customers with design. The zerooo reusable PET bottle was developed in tandem with the SEA ME GmbH team at ALPLA's in-house STUDIOa design centre at the company's headquarters in Hard.

Each zerooo reusable PET bottle is unique. A laser-engraved 2D data matrix code – the zerooo ID – provides information about the content and circulation history. „The digital labelling enables transparency and ensures the quality of the bottles. By combining it with the information from the label, it can also be complemented with further product data,“ explains Jörg Schwärzler, Senior Technology Manager at ALPLA. The reusable PET bottle is compatible with all automatic return systems. At the end of their life cycle, the bottles and caps are sorted and recycled.

ALPLA Group  
[www.alpla.com](http://www.alpla.com)

## Innovative Foreign Body Detection using X-Ray Technology

■ One of Sesotec's customers employs around 600 people in northern Germany and produces single and double-sided adhesive tapes on production facilities that are among the most modern in the world. These specialized products and adhesive solutions are an integral part of industrial manufacturing processes, especially in high-performance industries such as the automotive, electronics, paper, printing, construction supply, healthcare, and pharmaceutical industries. They are distributed globally, mainly to Europe, Asia, and America.

The production of adhesive tapes requires considerable experience, expertise, and commitment. Moreover, production must meet the high standards of various industrial suppliers. The plant in northern Germany is certified according to the environmental standard ISO 14001 and the quality standards ISO/TS 16949 and ISO 9001.

Raw materials for adhesive tape production can contain tiny metal particles. Even the smallest foreign object that enters production poses a significant risk. Essentially, the smaller the detected and removed particles, the better the protection against damage to processing machines and consumer complaints.

Even during incoming goods inspection, plastic processors can check raw materials for quality by using for-



foreign object detection systems. If foreign objects are detected and removed at the point of entry, value-added losses can be avoided, and the quality of the final products can be ensured.

In the plastics industry, the use of inductive metal detectors is often common and sufficient. However, the Sesotec customer was aiming for the highest possible sensitivity in metal detection. Initial tests were conducted with the most accurate metal detector available, but the





*The RAYCON X-ray system from Sesotec is a highly efficient device that achieves maximum detection accuracy (Image: Sesotec GmbH)*

results did not meet the client’s high expectations, who always strives for maximum quality. Thanks to Sesotec’s broad product portfolio, X-ray technology could also be tested – this turned out to be the desired solution.

Deciding whether metal detection technology or X-ray technology is the best choice was part of a comprehensive consultation process that Sesotec accompanied as a competent partner. Due to the desire for the highest detection accuracy, the client chose X-ray technology.

The RAYCON X-ray system from Sesotec is a highly efficient device that detects all foreign objects that absorb X-rays better than the surrounding product due to their density, chemical composition, or mechanical dimensions – in short, foreign objects denser than the actual product. Compared to conventional metal detectors, these systems offer the advantage of detecting a variety of dense foreign materials and working with a much higher detection resolution.

With the RAYCON, the client achieved the desired sensitivity. Metal particles that may be present in the raw material bags are reliably removed from the process, ensuring top-level quality.

Sesotec GmbH

[www.sesotec.com](http://www.sesotec.com)



[www.fimic.it](http://www.fimic.it)

**WE ARE FAST WE ARE FIMIC**  
WE MAKE THINGS HAPPEN



MEET US AT



AMI | Events  
Plastics Recycling  
Technology

Booth A6209

Booth 12

**FIMIC**  
ITALIAN MELT FILTER

## Vacuum and Leak Detection Solutions Introduced

■ Pfeiffer Vacuum introduced state-of-the-art vacuum and leak detection solutions for the hydrogen and fuel cell sector at this year's Hannover Messe in Germany.

### State-of-the-art mass spectrometer for gas and residual gas analysis

OmniStar GSD 350 is a compact, portable benchtop device which permits gas analysis at atmospheric pressure. It enables fast, reliable and precise measurement of non-condensable gases. The proven mass spectrometer software PV MassSpec provides qualitative and quantitative analyses. The systems cover the mass ranges 1 to 100 amu, 1 to 200 amu and 1 to 300 amu. This makes the OmniStar GSD 350 the fitting solution for material characterization tasks, such as hydrogen permeation testing through tank materials or sealing materials.

### Universal leak detector

The ASM 340 is a versatile leak detector for hydrogen and helium. The ASM 340 can be used not only for qualitative localization of leaks but also for quantitative integral or local testing. Its powerful vacuum system sets it apart and guarantees extremely fast operational readiness.

*ASM 340 from Pfeiffer Vacuum*



*OmniStar from Pfeiffer Vacuum*

It also features a rapid response time due to its high helium pumping speed. These characteristics result in short cycle times and a high throughput rate. The ASM 340 is the only leak detector in its class capable of locating leaks at pressures below 100 mbar. Leakage testing of fuel cell stacks, hydrogen tanks and integrated hydrogen circuits are a main focus.

### Mobile Leak Test Module

Pfeiffer Vacuum also presented a mobile Leak Test Module which offers a modular solution for leakage testing. With its individually configurable components, the mod-

ule is suitable for a wide range of leak testing tasks using helium and hydrogen/forming gas as tracer gases. Its many components permit a wide range of leak testing with tracer gases and make it individually configurable. Its optional automation capabilities make it the ideal solution for efficient and reliable leak testing at the preliminary development stage right up to the small series level.

And that's not all – Pfeiffer Vacuum also offers a special Leak Test Module for monopolar and bipolar plates. It can be fully integrated into existing production lines. With its multi-patented setup and process, the module results in short cycle times of under 40 seconds, thus supporting efficient production.

*Leak test module for leak testing monopolar or bipolar plates from Pfeiffer Vacuum*



Pfeiffer Vacuum GmbH  
[www.pfeiffer-vacuum.com](http://www.pfeiffer-vacuum.com)

# Portfolio Expanded

■ K.D. Feddersen and its European subsidiaries have been selling TRINSEO's thermoplastic elastomers since 2021. With ALTUGLASTM, a PMMA material is now also being added.

ALTUGLASTM has been a strong brand in the PMMA (polymethyl methacrylate) sector for over 70 years. TRINSEO took over the PMMA business from Arkema in 2021. In addition to an extensive range of universally applicable grades, the portfolio also includes chemically resistant and impact-modified PMMA as well as light-diffusing grades. According to the manufacturer, circular solutions based on chemically or mechanically recycled raw material components are also available with the ALTUGLASTM R-Life series.

"With the new PMMA grades, we can offer our customers a wide range of solutions for a variety of applications, such as in the automotive industry, for household appliances, consumer electronics, mechanical engineering, electrics & electronics or lighting technology," says Daniel Brock, Head of Marketing & Product Management EU at K.D. Feddersen.

The distributor sells the ALTUGLASTM product family in Germany, France, the Maghreb region, Austria, Swit-



*With its exceptional optical properties, PMMA is an ideal material for interior design and lighting (@kardaska/stock.adobe.com)*

zerland, Poland, Hungary, the Czech Republic, Slovakia, Romania, the UK and other European countries.

K.D. Feddersen GmbH & Co. KG  
[www.kdfeddersen.com](http://www.kdfeddersen.com)

# "ENSŌ" IN MIXING

*looking for perfection*



*in equipment manufacturing for*  
**PVC DRY-BLEND, MASTER BATCH, THERMOPLASTIC RUBBER, POWDER COATINGS, METALLIC BONDING and WPC**



**AMI Plastics World Expos NORTH AMERICA**  
Booth C310 Nov. 13-14, 2024 Cleveland, OH

**Plast Eurasia Istanbul 2024**  
23rd INTERNATIONAL ISTANBUL PLASTICS INDUSTRY FAIR  
December 4-7, 2024

**plasmec**  
*Excellence in Mixing*

PLAS MEC S.R.L.  
Via Europa 79, 21015 Lonate Pozzolo (VA) - Italy  
phone +39 0331 301648 - comm@plasmec.it  
[www.plasmec.it](http://www.plasmec.it)

## NEW 500 Series Rubber/Silicone Extrusion Crosshead

■ Guill Tool introduces the NEW 500 Series crosshead with MAGS gum space adjustment. The 500 Series is designed specifically for the flow characteristics and unique processing challenges of elastomeric compounds. One of the key features engineered by Guill on this new crosshead design is the mechanically assisted gum space (MAGS) adjustment system. This new method of gum space adjustment allows the operator to make an effortless adjustment from a single point using a common socket wrench. No more need to struggle with multiple nuts and bolts in order to adjust gum space, which leads to faster adjustments. The visual indicator on the core tube allows the operator to see how far the gum space has been moved, making those adjustments much more accurate and repeatable.

The hardware-free and patented cam lock design of the new 500 Series from Guill means no time is wasted unbolting and re-securing fasteners for disassembly and re-assembly. Only half of a rotation of the cam nut is required to loosen and automatically extract the deflector from the head body, which is another time saver. Also, with no undercuts on the deflector, there are no material hang-ups when extracting the deflector, allowing for faster and easier cleaning and changeover.

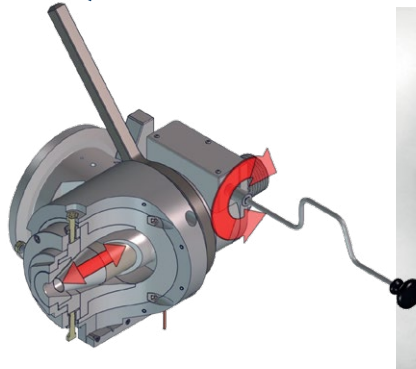

The new 500 Series also features the latest Center-Stage concentricity adjustment system that significantly reduces pressure on the tooling, allowing easier and more precise concentricity adjustments without loosening the face bolts. Easy-Out inserts for the adjusting bolts also allow simple replacement of locked or damaged adjusting bolts, which further saves on repair and downtime.

Another innovative feature of this new rubber/silicone crosshead is a cast aluminum liquid-fed cooling sleeve that allows the user to switch out the cooling jacket in the event of a line obstruction, again reducing downtime compared to traditional integrated cooling systems.

The new 500 Series crosshead with MAGS gum space adjustment is a drop-in replacement on most existing NRM lines, however this crosshead design can also be adapted to fit any extruder design or line layout.

The addition of a newly designed flow inlet channel reduces the shear

*Guill Series 500 crosshead with Mechanically Assisted Gum Space (MAGS) adjustment... specially designed for the flow characteristics of elastomeric compounds*

and heat that is generated as the materials are being processed. This leads to lower head pressures allowing the material to move through the head in a much more balanced and even flow.

All crossheads supplied by Guill are furnished with a tool kit for assembly and disassembly as well as a detailed operator's instruction manual. The engineering team at Guill will gladly assist users in the implementation and operation of the new 500 series crosshead.

For a video of the new Guill 500 Series crosshead with MAGS gum space adjustment:

► <https://youtu.be/jeNovmMtcBs>  
Guill Tool & Engineering  
Tom Baldock, [www.guill.com](http://www.guill.com)

## Standardized OPC UA Data Exchange for Peripheral Devices

■ The connection of production machines and peripherals within the production cell is of central importance for production efficiency and quality. Standardized data exchange offers optimal conditions for this through manufacturer-independent communication. For this reason, the Joint Working Group "Plastics and Rubber Machinery" is developing the EUROMAP 82 specification series for peripheral devices based on the global production language OPC UA. Two more parts of

this series have now been published as drafts:

- Part 4: Dosing systems
- Part 5: Moulds

As with the existing parts of the series, communication from peripheral devices to the production machine as well as to higher-level control systems is standardized. The specifications cover parameters for identification and configuration, automatic login of the machine user to the peripheral devices as well as the monitoring and control of process values.

In addition, the draft version 1.02 of Part 3: Liquid Silicone Dosing has been published. This version includes additional parameters to optimize standardized data exchange.

The Joint Working Group has also started work on Part 6: Granulate Dryer Devices. Interested companies are invited to actively participate in the working group.

The draft is available for public inspection as a free download at

► [www.euromap.org](http://www.euromap.org)

## New Management

■ Kiefel, a market-leading company for thermoforming and joining technology and a member of the Brückner Group, is undergoing a change in management: Matthias Sieverding, previously CEO/President of the Brückner Group's USA platform company, succeeded Thomas Halletz as CEO of Kiefel on September 1st. Sieverding, an experienced industry expert, will further drive the turnkey solution provider's innovation and internationalization course.

Over the company's almost 70 years of history, Kiefel has repeatedly successfully adapted to market changes with cutting-edge technological solutions. "Thanks to Thomas Halletz's pioneering spirit, Kiefel has grown significantly and achieved a strong position, which will now be further expanded," says Dr. Axel von Wiederberg, CEO of the Brückner Group. Under the leadership of Matthias Sieverding, Kiefel plans to expand its global presence and secure market leadership through a consistent customer focus. The innovative power of the product portfolio is to be strengthened through agile processes and procedures and the rapid integration of digital technologies in order to continue to set industry standards into the future. Underlining this strategic direction, Kiefel is presenting several groundbreaking machine innovations at the Kiefel Packaging Dialogue Days in October this year.

Matthias Sieverding has more than 25 years of experience in the international plastics and mechanical engineering industries. In 2021, he joined Brueckner Group USA, as the CEO/President of the group's regional platform company, which he significantly expanded to be more customer-centric. He has previously held various executive or managerial positions.

KIEFEL GmbH  
www.kiefel.com

Matthias Sieverding has been the new CEO at Kiefel since September 1, 2024 (© Kiefel GmbH)

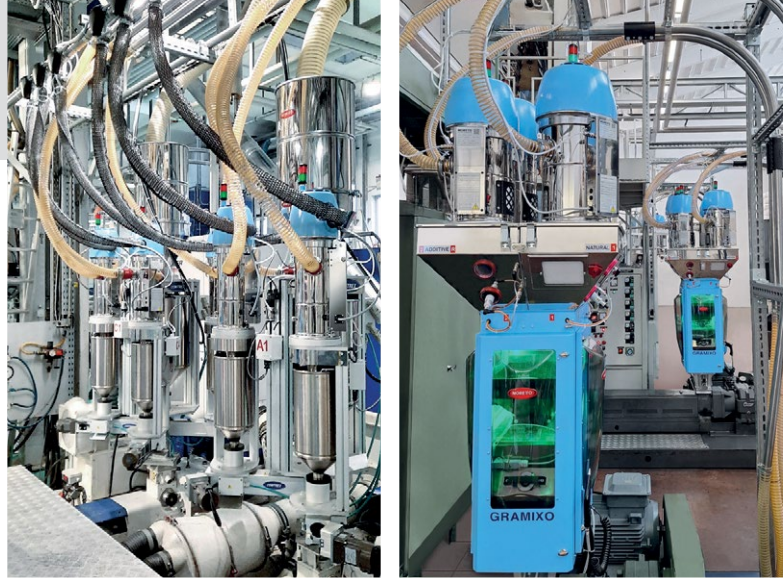

## AUTOMATIC CONTROL OF THE EXTRUSION PROCESS



a Moretto brand

contrex.it  
follow us

Hall B3  
Stand 3208

## wire MEXICO 2025 Dates Announced – Debut of Tube Mexico

■ The second staging of wire Mexico as part of the established Mexican trade fair Expo Manufactura will be held from February 11 to 13, 2025, at the CINTERMEX Centro Internacional de Negocios in Monterrey. New next year: the debut of Tube Mexico. After introducing wire Mexico in 2024, Messe Düsseldorf will add Tube Mexico 2025 as a new satellite event of its worldwide Metalflow Alliance trade fair portfolio. Expo Manufactura, the International Trade Fair for Manufacturing Technology, Automation and Robotics, has been held annually in Mexico since 1996 and is managed by the international organizer Informa Markets.

Messe Düsseldorf is renowned as the organizer of the world's No. 1 trade fairs wire and Tube, taking place every two years in Düsseldorf, Germany.

The wire & Tube Mexico 2025 trade fairs will offer international companies an important platform to enter the Latin American wire/cable and tube/pipe market. Especially Mexico is becoming increasingly important and is a key growth market for these industries. Growing investment in Mexican infrastructure, particularly from the automotive, electronics and energy sectors, is driving national demand for wire, cables, tubes, pipes and accessories. "At wire and Tube Mexico you will see global market leaders and trendsetters from the entire process chain. Meet at decision-making level for new impulses, networking, knowledge exchange and big business", stated Daniel Ryfisch, Director of Messe Düsseldorf's Metalflow Alliance portfolio.

Exhibit categories at wire Mexico include machinery for wire/cable manufacturing and processing, tools and auxiliary materials as well as wire/cable products, testing technology and software. Tube Mexico focuses on metallic tube and pipe manufacturing and processing machinery, tools, resource efficiency and OCTG.

To date, over 1,600 square meters of booth space have been reserved for wire and Tube Mexico 2025. Both trade fairs will feature country pavilions from Germany, Italy and Brazil. In addition, wire Mexico will include country group exhibits from Austria and France as well as a group stand organized by the International Wire and Machinery Association (IWMA).

The last Expo Manufactura in February 2024 attracted 503 exhibitors, presenting more than 1,000 brands during the three trade fair days. More than 19,500 visitors from 35 countries traveled to Mexico, primarily machinery manufacturers, suppliers, metal fabricators and experts from the electrical and automotive industries.

At the premiere of wire Mexico this year, 51 exhibitors from 12 countries presented their latest technologies and innovations on 580 square meters of exhibit space.

Messe Düsseldorf GmbH

Sarah Liehsem, LiehsemS@messe-duesseldorf.de

► <https://wire-tube-mexico.com/>

## 2024 Size and Impact Report: Plastics Industry Thrives, Vital to Job Creation, Economic Growth and Manufacturing

■ The Plastics Industry Association (PLASTICS) unveiled its 2024 Size and Impact Report, the association's flagship annual analysis of the plastics industry, highlighting continued positive contributions to the U.S. economy. Dr. Perc Pineda, Chief Economist at PLASTICS, presented an overview of the report's findings during an online Executive Briefing provided exclusively to PLASTICS members and members of the press. Highlights shared during today's briefing included:

- The U.S. plastics industry is large, accounting for over a million jobs (1,005,100) and \$519.1 billion in shipments in 2023.

- A success story for the U.S. economy, plastics manufacturing employment grew 1.1% per year from 2013 to 2023, outpacing total manufacturing, which saw employment grow by just 0.7% per year during the same period.

- When suppliers to the plastics industry are considered, plastics-related U.S. jobs grow to 1.55 million, and total shipments grow to \$658.2 billion.

- As measured by gross output, the plastic products portion of the plastics industry was the eighth largest U.S. industry in 2022 (the latest year for which data are available).

"This report shows the plastics industry remains vital to our economy as a job creator and a source of innovation," said PLASTICS President and CEO Matt Seaholm. "Our industry will continue to grow as part of the circular economy, finding innovative ways to make plastic better and more sustainable."

"The 2024 Size and Impact Report of the U.S. plastics industry highlights the vital role the industry plays in the economy," said PLASTICS' Chief Economist Dr. Perc Pineda. "The report shows growth in the industry's real economic value added (adjusted for inflation), an increase in its share of consumer demand, and, more importantly, a rise in annual payroll."

To request a copy of the Size and Impact Report Executive Summary please email:

► [Camillo Gallo, cgallo@plasticsindustry.org](mailto:Camillo.Gallo@plasticsindustry.org)

## Statement on Investments for New Recycling Sites in California

■ The Plastics Industry Association (PLASTICS) commends Governor Gavin Newsom’s announcement to invest in over 250 recycling sites across 30 counties in the state of California.

“We commend Governor Newsom’s investment in new recycling sites throughout California,” said PLASTICS President and CEO Matt Seaholm. “We believe investing in recycling infrastructure and advancing new technologies is the most effective path forward. Making recycling easier is key to increas-

ing recycling rates. “Almost a year ago, we launched our advocacy initiative, „Recycling is Real”, to show that recycling is happening across the country every day, including in California. We appreciate Governor Newsom’s commitment to recycling and the crucial role recycling plays in keeping waste out of the environment. Our industry remains committed to working together with lawmakers in California and across the U.S. to develop and enact effective policies that will protect our environment and get recy-



Matt Seaholm

cling rates where we all want them to be.”

## Introduction of Bipartisan Legislation to Modernize Recycling Infrastructure Applauded

PLASTICS applauds the introduction of the Accelerating a Circular Economy for Plastics and Recycling Innovation Act (H.R. 9676). This legislation introduced by Representatives Larry Bucshon (R-IN) and Don Davis (D-NC), aims to modernize the nation’s recycling infrastructure, spur innovation and reduce plastic waste.

“This legislation is a step in the right direction, and we applaud the

leadership of Rep. Larry Bucshon and Rep. Don Davis for introducing a bill that recognizes the essential role plastic material plays in our daily lives and addresses comprehensive plastics recycling,” said PLASTICS President and CEO Matt Seaholm. “Modernizing the country’s recycling infrastructure and developing end markets for recycled material are critical to increasing recycling rates and ensuring that

plastic waste stays in our economy and out of the environment. We look forward to working together with legislators in Washington to achieve our shared sustainability goals and ultimately get a bill to the President’s desk.”

The Plastics Industry Association (PLASTICS)

➔ [www.plasticsindustry.org](http://www.plasticsindustry.org)

## New ASM for the Americas Appointed

■ Global leader and pioneer of surface treatment technology Vetaphone A/S has appointed Marcus Knapp as its new Area Sales Manager (ASM) for North, Central, and South America. He will work alongside Vetaphone’s well-established and highly-experienced agent network in the region to develop the company’s fast-growing business, especially in the US.

Originally from Charlotte, NC, prior to joining Vetaphone Marcus held managerial positions in the hospitality sector where he was a group coordinator and work environment representative, and it’s this background that made him an attractive candidate for the ASM position.



Marcus Knapp is Vetaphone’s new ASM for America

Speaking for Vetaphone, CSO Kevin McKell said: “We are delighted that Marcus has joined us to help

grow our business in America – he brings a different set of skills to our operation which will be invaluable as we ramp up our activity in the US.”

In response Marcus stated: “It is a privilege to join the global market leader in surface treatment and be able to draw on their unmatched expertise in corona technology - I’m looking forward to meeting up with my American colleagues at the upcoming Labelexpo in Chicago.”

Married and with family in Denmark and the US, Marcus is a regular trans-Atlantic commuter, which fits well with his new job.

Vetaphone A/S

➔ [www.vetaphone.com](http://www.vetaphone.com)

## 50 Years of Operational Excellence Celebrated

■ SI Group announced the 50th anniversary of its Freeport, Texas manufacturing facility. This milestone represents a half century of dedication to excellence in manufacturing and commitment to the community. To mark this special occasion, SI Group hosted its annual fishing tournament and family picnic on September 14, 2024. The event showcased the spirit of the company's Texas-based team with an impressive turnout and a partnership with a local charity, featuring a generous donation to celebrate 50 years.

Established in 1974, the company's Freeport, Texas manufacturing facility remains a major production site for SI Group's operations in the U.S. This world-class alkyphenol plant serves customers globally, supported by a workforce of over 100 employees known for their resilience and industry-leading expertise. Even through difficult times such as winter storm Uri, Hurricane Beryl, and other major weather events, the site takes pride in striving for operational excellence while caring for one another, their customers, and the community they serve. SI Group Freeport has been awarded the TCC Caring for Texas Award for five consecutive years, recognizing its outstanding achievements in safety, community involvement, and industry leadership.

This year's annual fishing tournament and family picnic was all about celebrating SI Group Freeport's significant milestone of 50 years in operation. The event brought together company leadership, current and retired employees with their families, and community members for a day of camaraderie and fun. This cherished tradition culminated in a final catch weigh-in celebration with participants, highlighting the site's deep roots in Brazoria County and its longstanding commitment to employees and their families.

In honor of 50 years, SI Group partnered with the Dream Gifts Program to donate 50 bikes to children in



Brazoria County. In addition to this donation, SI Group employees volunteer their time to various charities and community organizations throughout the year.

"Celebrating this achievement would not have been possible without the dedication of our employees – past and present – who have worked tirelessly to shape our journey," said Paul Tilley, SVP, Business Development. "SI Group has established deep ties within the community, and we're proud to have contributed to growth in the local economy through job creation and partnerships."

SI Group is committed to innovation and excellence while fostering strong community relationships. The Freeport facility reflects the company's values and dedication to serving both customers and the community.

SI Group

www.siigroup.com

## Radiation Service Provider Expands into the USA

■ The medium-sized company BGS Beta-Gamma-Service, which has specialised in radiation sterilisation and radiation crosslinking for more than 40 years, is expanding into the USA: with its new location in Pittsburgh, Pennsylvania, BGS is focusing on fully automated radiation treatment with e-beam. The aim is to establish a safe and powerful alternative to gamma and EtO sterilisation for medical devices. BGS US will commence operations in the middle of next year.

The USA is the world's largest and most innovative market for medical technology and continues to show



dynamic growth. This increases the demand for sterile medical devices and reliably available sterilisation capacities. Historically, the two technologies gamma irradiation

and EtO treatment have strongly dominated the US market for sterilisation. The supply situation is exacerbated by uncertainties regarding the environmental hazards of EtO





*BGS Beta-Gamma-Service is expanding into the USA under its Managing Director Dr Andreas Ostrowicki. Leonard Zuba, formerly Vice President of Sales at Raumedic, Inc., takes over the management of BGS US LLC. From the left: Leonard Zuba, Dr Andreas Ostrowicki (Photo: BGS/Lina Sommer)*

and the supply of cobalt-60, which has become more difficult in recent years. Modern alternatives such as

e-beam sterilisation are much less widespread in the USA.

With the fully automated radiation treatment with e-beam, BGS is now creating additional capacity: "The availability of sterilisation capacity poses major challenges for US medical technology manufacturers, which means that supply bottlenecks are a recurring threat. With our new plant in Pittsburgh, we are helping to close this gap," explains Dr Andreas Ostrowicki, Managing Director of BGS Beta-Gamma-Service.

BGS US relies on a tried-and-tested process and the latest technology: the new site will be equipped

with highly efficient electron accelerator technology combined with fully automated product handling. The facility in Pittsburgh, PA, is scheduled to open in 2025 and will operate under the name BGS US LLC. The Managing Director is Leonard Zuba, formerly Vice President of Sales at Raumedic, Inc. "Sterilisation with ionising radiation is one of the most common technologies for sterilising medical devices, pharmaceutical primary packaging and products for biotechnology. My goal as Managing Director of BGS US is to further promote e-beam as a highly efficient sterilisation method for US manufacturers," explains Zuba. Bert Whitt, who has many years of experience in the radiation sterilisation of medical products, will take over as site manager.

**BGS Beta-Gamma-Service GmbH & Co. KG**

➔ [www.bgs.eu](http://www.bgs.eu)

## New Managing Director for Americas

■ ■ Henning Karbstein took over the management of KRAIBURG TPE for the North, Central and South America region ("Americas") as of October 1, 2024. Karbstein will be managing the operational business of the global TPE manufacturer from its U.S. location in Atlanta, Georgia. He has already been receiving extensive training and an introduction to his new areas of responsibility since April 1, 2024 – both at the head office of the U.S. branch and at the company's headquarters in Waldkraiburg, Bavaria, Germany. He will have full operational scope in his new position from the start of the fourth quarter of 2024.

Karbstein took over the position and duties from his predecessor, Jeff Frankish. Frankish has successfully conducted his role as managing director for 17 years and retired after a six-month transition phase that ended on September 30, 2024.

Oliver Zintner, CEO at KRAIBURG TPE: "Jeff has done pioneering work in the Americas and has advanced the development of our business areas there at a high level. This and his extraordinary presence

have left lasting traces on the whole company. However, we are confident that his successor, Henning Karbstein, will continue on this path to success in the best tradition and, with his management and industry expertise from the automotive and engineering industry, will take us to the next stages of development in America in the coming years."

After graduating in 1996 in mechanical engineering in Karlsruhe, Germany, Hennig Karbstein started his professional career at Schaeffler Group, an automotive Tier-1 supplier based in Herzogenaurach, Germany. In 2005, he moved to Schaeffler Group USA in Fort Mill, South Carolina, and took over the position of Lean Process Manager in 2007, for the headquarter at that site and for all the production plants in North America. In 2012, Mr. Karbstein moved to North Carolina, from Schaeffler to BASF Corporation in Charlotte, where as Manager for New Business Development & Idea Management, Dispersion and Resins, he was responsible for the division's business development in North America. In 2019, he switched



*Henning Karbstein  
(Image: © 2024 KRAIBURG TPE)*

to Badische Stahl Engineering in Charlotte, where as Vice-President of Sales, he was responsible for the North American region.

Henning Karbstein: "KRAIBURG TPE has long been established as a major player in the plastics processing industry in the region. Going forward, I want to contribute to expanding our business activities in North, Central and South America even further so that we can gradually unlock our full potential there."

**KRAIBURG TPE**

➔ [www.kraiburg-tpe.com](http://www.kraiburg-tpe.com)

## ‘Recycling is Real’ Marks One-Year Milestone with New Video

■ The Plastics Industry Association (PLASTICS) has unveiled a new video as part of the ‘Recycling is Real’ advocacy campaign, marking the campaign’s one-year milestone dedicated to promoting and defending plastic recycling in America. The new video highlights the efforts taking place at Commercial Plastics Recycling (CPR) Inc. in Tampa, Florida.

PLASTICS’ ‘Recycling is Real’ campaign has highlighted mechanical and advanced recycling facilities throughout the United States. Employees in each video who represent the recycling industry and the work that they do are featured at locations including Atlanta, GA; Madison, WI; North Vernon, IN; Baton Rouge, LA; Portland, PA; Eagle Rock, VA; Rialto, CA; Wytheville, VA; Piqua, OH; Reidsville, NC; and Farmingdale, NY.

“Plastic recycling is very real, and Commercial Plastics Recycling

(CPR) Inc. does it every day in Tampa, Florida,” said PLASTICS’ President and CEO Matt Seaholm. “For the past year now, the Recycling is Real campaign has been highlighting the dedicated people of our industry across America who work to recycle valuable materials. We are committed to continuing to show the public and lawmakers that recycling is undeniable, and a feasible and economical way to achieve a more circular economy.”

“Plastic recycling is CPR’s commitment to our future generations,” said CPR, Inc.’s Plant Manager, Jeff Barksdale. “Our commitment today changes the world tomorrow. Recycling is Real!”

The Recycling is Real campaign provides content to help elected officials and policymakers understand that recycling is a vital link of the sustainability and circularity chain, enabling them to make more



well-informed decisions about recycling resources for their constituents. The campaign was also created in an effort to put an end to false narratives suggesting recycling is not actually happening or claiming that recycling is a “myth.” Recycling has come under attack from those who wish to reduce or eliminate the production of plastic altogether. ‘Recycling is Real’ shows how recycling happens, where it happens and introduces the people who make it happen.

To view ‘Recycling is Real’ featuring CPR:

▶ <https://recyclingisreal.com/>

## Plans to Close Manufacturing Site in Singapore Announced

■ SI Group announced its plans to close its alkylphenol manufacturing facility located on Jurong Island in Singapore in the second half of 2025. SI Group will continue supplying alkylphenols from its market-leading global footprint with supply points in both Europe and the Americas.

SI Group opened its alkylphenol manufacturing plant on Jurong Island in 2006 to provide alkylphenols to Asia-Pacific consumers and for production of SI Group antioxidant products. Yet, due to the substantial changes in the antioxidant value chain in the region in recent years, paired with high costs in Singapore, the company will cease production there next year. “SI Group’s manufacturing facility in Singapore has been a valuable asset for our past growth and global presence,” said Joey Gullion, SVP & Chief Commercial Officer at SI Group. “However, the current supply-demand balances in Asia and the cost to manufacture in the region, make this a necessary move to ensure the long-term sustainability of our global business.”

As a global leader in performance additives, SI Group remains committed to being a value-added solutions

provider to customers worldwide, including those in Asia-Pacific. With alkylphenol manufacturing facilities in Europe and the Americas, SI Group will maintain its alkylphenol market leadership and uphold its customer and technical service support levels.

“We’ve shifted our strategy in Asia-Pacific to better serve our customers’ needs. The region is important to our business, and we believe this new approach will help us balance the market dynamics with our cost position,” said David Bradley, President & CEO of SI Group. “Our recent partnership with Dingjide, along with the difficult but essential decision to close our Singapore site, underscores our commitment to serving our customers – we are now better equipped and excited to support our customers’ growth, both now and in the future.”

SI Group’s Singapore manufacturing facility is expected to cease manufacturing operations in the second half of 2025. The company will provide support and assistance to all employees impacted by the plant closure.

SI Group

▶ [www.siigroup.com](http://www.siigroup.com)

## Economic Analysis: Revised Employment Statistics Impact on Plastics

■ PLASTICS has released an official analysis of the impact of revised employment statistics and the policy implications on the plastics industry, authored by PLASTICS Chief Economist, Dr. Perc Pineda.

Dr. Pineda writes, "The lower employment rate in manufacturing suggests reduced manufacturing activity, which can have ripple effects both upstream and downstream. For plastics and rubber product manufac-

turing, the preliminary employment estimate for July was 724,000, nearly matching the monthly average of 725,300 in 2021."

To read the full analysis on the PLASTICS blog page:

➔ <https://www.plasticsindustry.org/blog/revised-employment-statistics-and-the-policy-implications-on-plastics/>



Dr. Perc Pineda

## Winner of the Plastics Industry Association Bioplastics Innovation Award

■ The Plastics Industry Association (PLASTICS) announced Floreon Technologies Ltd., as the winner of PLASTICS' 2024 Innovation in Bioplastics Award. The announcement came as part of PLASTICS' ninth annual „Bioplastics Week“ event.

Floreon Technologies received the award for their „Floreon Therma-Tech“ product, a UL94V-0 rated, halogen-free fire-resistant PLA-based compound. The product offers the performance of styrenic polymers but with a renewable feedstock and low carbon footprint.

Patrick Krieger, PLASTICS' Vice President of Sustainability congratulated Floreon Technologies Ltd., saying, "Innovation is about providing people with more options, not less. Floreon Therma-Tech offers companies that want to use biobased materials in durable applications, like building and construction, with sustainable attributes from beginning to end of life." "2024 is our year – we've scaled up three products: Floreon

Therma-Tech, Dura-Tech and Bio-Tech, brought new talent onboard and successfully launched our first commercial application. Being recognized by our peers in the bioplastics space highlights that the industry shares our excitement for the technology's far-reaching potential," says Sandrine Garnier, CEO of Floreon. "Winning this award is testament to the relentless innovation and commitment of the entire Floreon team and the significance of the breakthrough we've made in developing a plant-based, halogen-free, flame retardant, recyclable bioplastic for high-performance engineering end-uses."

According to Floreon Technologies, Floreon Therma-Tech is developed for applications requiring a sustainable alternative to oil-based plastic requiring fire resistance. Its durability is comparable to flame retarded ABS. With Floreon Therma-Tech there is no loss of function or performance but with a gain of a lower carbon footprint of up to seven times.

The submission window for the 2025 Innovation in Bioplastics Award will open in May 2025 and interested PLASTICS member companies can submit their innovations for consideration here.

Floreon has been pioneering plant-based plastics since 2011 with a mission to harness a solution that performed in the same way as oil-based plastics but with sustainable end-of-life options. Floreon has advanced research and development in this area by making renewable compounds that avoid 'downcycling' and can be used for exceptionally demanding engineering applications. Floreon bio-based technology results in a carbon footprint that is seven times lower than traditional oil-based derivatives. It enables end-user manufacturers to drive down Scope 2 and 3 emissions due to less energy intensive operations – reducing processing temperatures by up to 40°.

[www.floreon.com](http://www.floreon.com)

➔ [www.plasticsindustry.org](http://www.plasticsindustry.org)

# Flying High and More: *Fascinating Highlights at Fakuma 2024*



This year's Fakuma, the international trade fair for plastics processing, will be reaching new heights in the literal sense of the word from 15 to 19 October 2024: For example, Career Friday participants can win one of two vouchers for a 60-minute zeppelin flight for two. The programme also includes other attractive highlights: the second edition of the „Round Table at Fakuma‘ discussion format, this time on the topic of ‘Digitalisation – Top or Flop?’, a future-oriented start-up area, an exhibitor forum with top-class expert presentations and the presentation of the ‘cradle to cradle’ design concept at the opening press conference.

The plastics processing industry is looking forward to the highlight of the autumn – Fakuma 2024 in Friedrichshafen, Germany. It will be the 29th iteration of this international trade event, which is one of the most important trade fairs of the year for many companies. The industry highlight in the form of a hands-on trade fair maintains a familiar atmosphere with a high degree of internationality. „Last year, we welcomed 1,636 visitors from 40 countries in twelve halls, with foreign participants making up 38 per cent, and similar numbers are expected this year,” says Annemarie Schur, Fakuma project manager for exhibition organiser P. E. Schall. „Twelve halls plus the two East and West foyers will be in use for the event. As always, Friedrichshafen will be packed and we’re looking forward to it!”

## **Career Friday: Discover plastics processing and win a zeppelin flight**

For the first time this year, the exhibition organiser, the exhibitor advisory board and the exhibitors are organis-

ing a Career Friday for pupils, students and young professionals under the motto „Mould your dreams, mould your future“. The campaign aims to inform young people about career opportunities in the plastics industry and teach them about plastics at the same time. „Plastics are enormously important. They are indispensable and they also offer career opportunities – this is what we want to talk about on Career Friday,” explains Bettina Schall, managing director for exhibition organiser P. E. Schall. „The exhibitors will provide young visitors to the trade fair with an insight into the world of plastics processing, product development, new technologies and work processes. This will spark a great deal of enthusiasm for plastics and people will want to get involved in this industry of the future,” says the trade fair manager confidently. „All pupils, teachers, students, young professionals and young people are cordially invited to visit Fakuma on 18 October 2024.” As many of the target audience as possible are encouraged to attend, as a spectacular flight awaits: participants of the career information day can win one of two vouchers for a 60-minute zeppelin flight for two. The winners will be drawn on 18 October at 4pm.

The campaign is already taking shape. Plastics Europe Germany is preparing a guided tour: the theme is ‘Circular Economy’, and takes participants on a tour of the trade fair along the entire value chain from granulate to product and back again. Participants can expect many exciting encounters on their journey.

## **„Round Table at Fakuma 2024“: Experts discuss digitalisation**

Another highlight of this year’s trade fair is the second edition of the „Round Table at Fakuma“ on 15

October 2024. This time, the panel will be discussing digitalisation in plastics processing. Under the heading 'Digitalisation – Top or Flop?', a select group of experts will discuss which digital tools can really help the plastics industry meet the challenges ahead.

The five panellists will assess the state of digitalisation in the industry. The panel will examine the extent to which digitalisation offers solutions in the areas of sustainability and the shortage of skilled workers. All interested parties are invited to attend the discussion; participation is free of charge.

### Future-oriented topics – Start-ups with novel approaches

Fakuma will also give new impetus to the goal of sustainability. This means designing products holistically and promoting recycling and degradability. 'Design for recycling', for example, is becoming more tangible in the way products get made. The increasing use of circular rather than fossil raw materials is also a key aspect. Sustainable solutions for packaging, recycling compounds and metal substitutes will be on show, as will grinding and crushing machinery, cooling systems and energy-efficient tool temperature control technology, process monitoring and data acquisition systems, and innovations in industrial 3D printing. Trade visitors can expect to see ground-breaking ideas on how to tackle the specific challenges facing the industry in the start-up area and exhibitor forum. Fakuma has traditionally been a platform where processors can get answers to their questions and learn how to improve their operations and position themselves optimally for the future.

### The big goals: greater efficiency and sustainability

Efficiency is clearly a key focus at Fakuma 2024 on several levels: even greater energy efficiency, absolute resource efficiency, consistent process efficiency, and even greater plant operating efficiency. The challenge is performing many tasks simultaneously. But at a time when there is a shortage of skilled labour and costs are rising, plastics processors need to pull out all the stops to realise their potential. This is the only way that they will be able to survive in a competitive environment. This is why we can also expect to see exciting innovations in injection moulding technology. In addition to increasing efficiency, the goals of process stability, reproducibility and minimising set-up times are also driving development. After all, the ultimate goal is to achieve the lowest possible unit cost. Plastics processors achieve this through technical and organisational measures, as well as investment. The exhibitors at Fakuma have the right solutions to address these needs.

P.E. Schall GmbH & Co. KG

<https://www.fakuma-messe.de/en/>

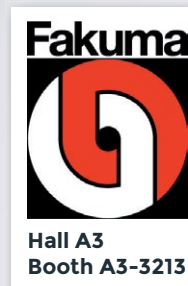

## EXPAND YOUR CAPABILITIES



Your competent partner in  
plastics processing mixing,  
dosing, conveying and drying  
Made in Germany

[www.koch-technik.com](http://www.koch-technik.com)



# Cutting-Edge Solutions for Efficiency and Sustainability

**F**AKUMA will bring together exhibitors from around the world to address the pressing challenges of efficiency, resource conservation, and sustainability. motan will be presenting exciting new additions to its portfolio of reliable and precise gain-in-weight dosing and mixing units, particularly for the medical and pharmaceutical sectors. Additionally, the motan Group will highlight its swift brand, known for combining high quality with exceptional price-performance ratios.

motan has long been committed to optimizing efficiency across its products and processes, focusing on material flow and sustainability. At this year's FAKUMA, efficiency takes center stage, encompassing not only materials and energy but also the operation of production facilities and entire production processes. Achieving seamless production requires a holistic approach where every step is meticulously interlinked, using sustainable materials and energy-saving products. Efficiency at all levels is the key to unlocking a company's highest and most sustainable potential.



*GRAVICOLOR 310/610 – Flexible and reliable granulate dosing (All pictures: motan group)*

## Advanced dosing and mixing solutions

The GRAVICOLOR 310 and 610 gravimetric dosing and mixing units feature motan's unique cone dosing system, allowing precise



*GRAVICOLOR 110 med – The FDA-compliant solution for dosing and mixing plastic granulate for the medical and pharmaceutical industry*

mixing of up to eight materials with recipe accuracy. Their modular design ensures optimal performance, flexibility, and reliability in injection moulding, blow moulding, and especially extrusion applications.

For the medical and pharmaceutical industries, motan introduces the GRAVICOLOR 110 med. This FDA-compliant unit, designed for injection moulding, blow moulding, and extrusion, utilizes vertical slide technology for precise mixing of up to four materials, ensuring maximum recipe accuracy.

All GRAVICOLOR units are equipped with the enhanced IntelliBlend analysis function, which records and documents recipes, materials, and operating environments. This self-optimizing system ensures users achieve the best possible working point continuously.

## swift brand

The motan Group's swift brand will showcase several standout prod-

*sDRY 250 – Flexible use with high capacity*



*sCOMPACT – Compact dryer with integrated conveying*





sCONVEY HOS – Cost-effective and efficient conveying process automation

ucts, emphasizing simplicity and efficiency:

- sDRY 250 dry air generator: It offers energy efficient drying with excellent dewpoints and many advanced features as standard.

- sCOMPACT dry air dryer: Available in various sizes, perfect for single or twin processing machine applications. The flexible dryer with integrated conveying and the option of controlling a dosing & mixing unit via its full colour touch display.

- sCONVEY HOS material loaders: Cost-effective and efficient conveying process automation.

- sCOLOR V additive dosing & mixing unit: Ideal for masterbatch and regrind dosing applications, offering quick delivery and cost-effective performance.

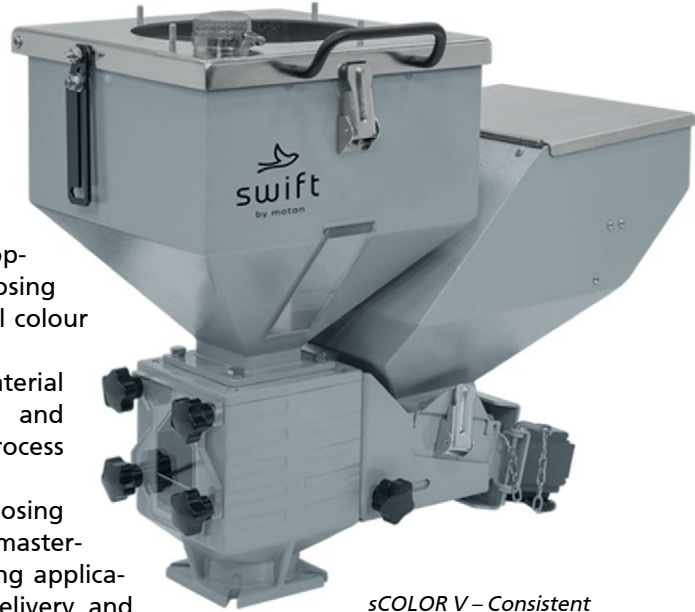

sCOLOR V – Consistent and accurate masterbatch dosing

### Promoting holistic process understanding

Process efficiency is rooted in the effective operation of production systems. Through the motan academy, users can receive comprehensive training that extends beyond machine operation. The academy offers basic and advanced seminars on

the theory and practice of materials management, ensuring a thorough understanding of technology, functionality, and the impact of settings on the entire production process.

motan holding gmbh  
www.motan-group.com  
Fakuma: Booth B1-1111

**Schönenberger**®

leading in premium knives

HIGH QUALITY  
MADE IN GERMANY

www.schoenenberger-messer.de  
mail@schoenenberger-messer.de  
+ 49 7153 82 84 0

# Versatile Recycling Technologies to Meet Increasing Expectations

Despite the tension felt by the plastics recycling market in Europe, new legislation provides reason for optimism. Recycling machine manufacturer EREMA has invested in the very latest technologies in recent years to pave the way for a plastics circular economy. Trade fair visitors interested in the latest processes can discover the company's extensive product portfolio at Fakuma.

"We see new legal requirements such as the PPWR as an opportunity to demonstrate our expertise. The European recycling industry has the know-how to meet these requirements, which gives Europe a significant competitive advantage," says Markus Huber-Lindinger, Managing Director at EREMA, in the run-up to Fakuma. The new EU PPWR (Packaging and Packaging Waste Regulation) prescribes a significant increase in the proportion of recyclates used to make packaging products by 2030. In other sectors, such as the automotive industry, the European Commission and well-known manufacturers are also calling for a higher proportion of recycled materials. State-of-the-art recycling processes are needed to achieve the necessary quality standards and provide a consistent supply of recycled pellets.

Innovative solutions are needed to achieve the recycling quotas in the food grade packaging sector. Over the past 25 years, the VACUREMA® series of machines has become established for the production of food-safe rPET. EREMA technologies for the recycling of PO materials (polyolefins) have also already been approved by an American food safety authority: the combination of the INTAREMA® TVEplus® with the ReFresher module allows recycled PO pellets from defined input streams to be reused in food packaging in proportions of up to 100 percent. By decontaminating the plastic and removing unwanted odours effec-



*Markus Huber-Lindinger, Managing Director at EREMA, is certain that the required recycling quotas in the EU can be achieved using innovative EREMA recycling solutions and the combined effort of European industry (Photo credits: EREMA GmbH)*

tively, the technology opens up further high-quality applications for recycled pellets made using collected post-consumer material. These can be used in the automotive, home and design products, and for sensitive personal care products, for example. In the EU, the permit for food-safe recycled pellets is based on a "novel technology". EREMA supports recycling companies in generating data and evidence for the EFSA (European Food Safety Authority) assessment process.

As the demand for recyclates increases, so does the need to expand capacities by using larger machines.

*INTAREMA® TVEplus® technology combined with the ReFresher anti-odour system is ideal for producing recycled pellets for food packaging and other high-quality applications*

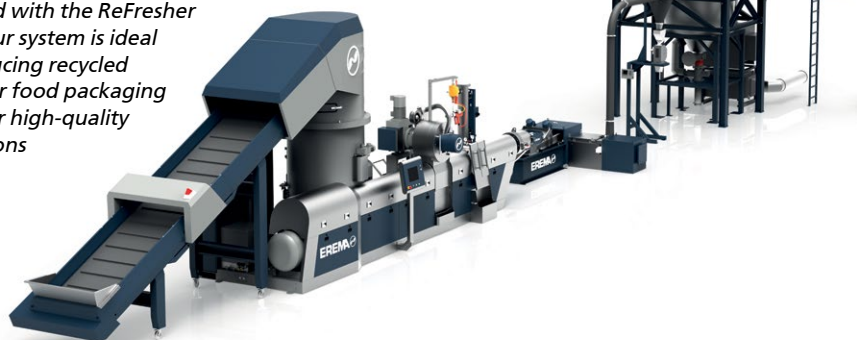

For recycling PET materials, EREMA supplies large-scale systems with throughputs of up to 6 tonnes per hour. The company has also built machines for recycling polyolefins with a throughput of over 4 tonnes per hour.

In addition to throughput, material-specific processes are decisive for increasing recycling capacities. EREMA's extensive range of products also includes solutions for compounding, such as the COREMA® series, which combines an EREMA extruder with twin screw technology. PCU TwinScrew technology, which features a direct combination of the patented PreConditioning Unit (PCU) and a twin screw extruder, is also ready to take on challenging homogenisation processes. These machines, as well as the new DuaFil® Compact and various filter solutions, are available for trials at the EREMA Customer Centre and in the R&D lab. "This wide selection of technologies is necessary to achieve an efficient recycling process because the method needs to be matched to the specific polymer, degree of contamination, input material and the application that the recycled pellets will be used for," explains Huber-Lindinger.

Digital assistance systems also make a major contribution to efficiency in plastics recycling. BluPort is EREMA's online customer platform that is viewed



as cutting edge in the recycling industry. BluPort contains apps for quality control and machine maintenance. The PredictOn app, for example, collects real-time data and enables predictions to be made about upcoming maintenance work, which

increases machine uptime and productivity. The Spare Parts Online App makes it much easier to order spare parts. EREMA launched the platform at K 2016. Since then, the number of EREMA customers using the BluPort platform has increased continuously,

with the number of new users almost tripling over the past three years.

EREMA Group  
[www.erima.com](http://www.erima.com)  
 Fakuma: Booth A6-6314

# New Series of OMNI Recycling Lines – Revolutionary Degassing and Decontamination Technologies Open Up Expanded Application Opportunities

The Gneuss MRS Extrusion Technology is well known as an alternative for the recycling of contaminated materials such as Polyester (PET), Polystyrene (PS), Polypropylene (PP) or Polyethylene (PE). In combination with Gneuss' highly efficient Rotary Filtration Systems, optimised vacuum technology, an Online Viscometer VIS and Gneuss measurement technology, customisable recycling lines can be designed for a specific material. As an option, material can be fed to the extruder via a 3C Rotary Feeder.

Multiple Letters of Non-Objection (LNOs) from US-American food & safety authorities, EFSA compliance and local approvals in Latin America confirm the decontamination efficiency of the technology.



Typical applications for OMNI recycling machines include the processing of PET scrap, such as bottles, sheet regrind or fibre waste, into high quality end products such as thermoformed sheet (suitable for food contact), staple fibre, POY, FDY, BCF or strapping. In addition,

*Gneuss OMNImax recycling machine with MRS extruder and RSFgenius filtration system*

a wide range of raw materials such as PS, PP, PE, PLA can be recycled. The OMNI series is also used in the decontamination of post-consumer

► **Universally applicable – Optimised for your needs.**

No matter if you are manufacturing metallised standard food and non-food packaging, easy-to-recycle stand-up pouches from MOPE film or technical products, SML's cast film lines are always optimised for your specific requirements.

**Extrusion lines.**  
Engineered to perform.

Learn more about  
**SML's cast film lines.**

[www.sml.at](http://www.sml.at)

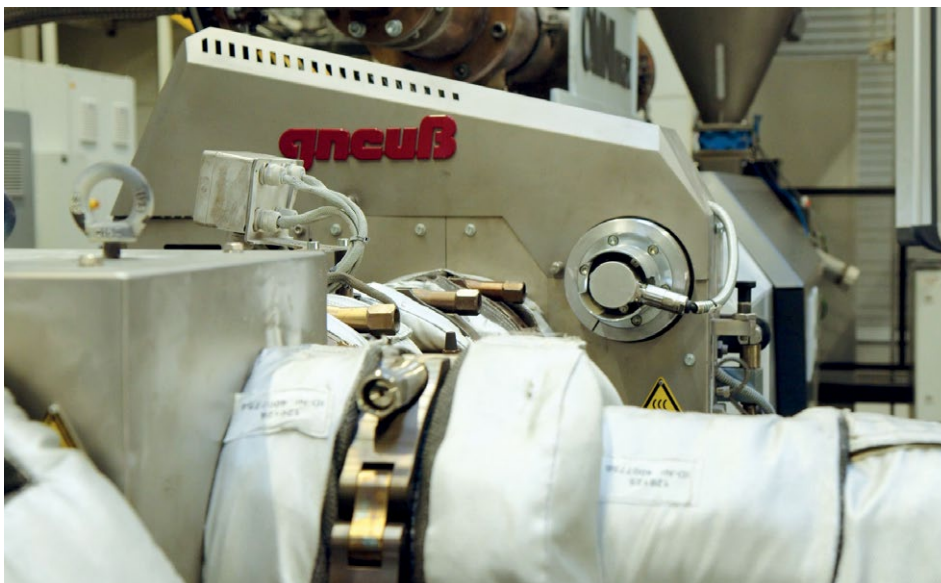

Patented Rotary Filtration System RSFgenius

waste for the production of direct food contact products such as HDPE bottle caps, coffee caps and for odour reduction and degassing of PA, SAN or other polymers.

In addition to its compact design, which takes up very little space and can therefore usually be easily integrated into existing premises, the OMNI scores highly in terms of flexibility. The fully automatic control of vacuum, extruder, dosing, degassing time and filter change ensures a consistently high quality of the end product while allowing the operator to use lower cost raw materials. In today's tight and fluctuating materials market, it is becoming increasingly important to be able to produce regardless of the properties of the input materials, especially in the future when the quality of the input materials will vary and be uncertain.

The compact design also results in very low energy consumption. Any energy used in the extrusion process is designed to be used in the next process step. This not only has a noticeable effect on electricity and gas consumption, but also significantly reduces the CO<sub>2</sub> footprint of the recycling process.

### Multiple Screw Extruder MRS

The MRS extruder is based on conventional single screw technol-

ogy but is equipped with a multiple screw section for devolatilization. It enables very efficient and gentle decontamination of the polymer melt, whilst achieving the requirements for direct food contact standards. In addition, the MRS extruder permits the processing of R-PET directly into high quality end products such as packaging sheet, strapping tape or filaments without pre-drying by using a simple and rugged vacuum system. All this is achieved by means of its unique and patented processing section. The Multi Rotation Section is a drum containing multiple satellite single screws, driven by a ring gear and pinion transmission.

The satellite screws rotate in the opposite direction to the main screw. This disproportionately increases the surface exchange of the polymer melt. A large opening for venting, exposing the full length of the satellite screws, is completely under vacuum. This provides excellent and unrestricted access to the polymer melt, the surface of which is constantly replaced at an extremely high rate by the action of the satellite screws in the multiple screw section. The surface area – and the surface area exchange rate – available for devolatilization are far greater than in other extrusion systems. As the thermal and mechanical stress on the polymer melt is minimized, reclaim processed on the MRS extruder has excellent optical and mechanical properties.

In a single, simple extrusion step, harmful contaminants can be removed so thoroughly that the resulting recycled pellets are safe for use in food contact applications.

### Vacuum System

Gneuss has developed its own vacuum systems for the extraction of volatile impurities, some of which have patented separation systems. Due to the large melt surface in the MRS extruder, the suction capacity is considerably higher than in conventional systems, so that large quantities of volatile impurities can be

extracted from the polymer and separated from the vacuum flow by means of automated separator systems. In addition to a water ring pump vacuum system, Gneuss also offers deep vacuum systems with appropriate separators.

The vacuum system on display is a water ring pump system designed for vacuums of

25-40 mbar and offers high automation and process control with low maintenance, even in recycling applications.

### Gneuss Filtration Technology

Gneuss' top model, the RSFgenius, operates with an integrated back-flushing system offering self-cleaning for very demanding applications and highest quality requirements. Screens can be automatically reused up to 400 times and filtration finenesses below 10 microns/1200 mesh are available.

Retrofitting a fully-automatic RSFgenius to an existing extrusion line, whether in a pelletizing, sheet, fiber or pipe application, permits the use of more contaminated (and often cheaper) material and/or the use of finer screens. Every retrofit is tailor-made and usually without the need to move any existing equipment.

Gneuss Kunststofftechnik GmbH

► [www.gneuss.com](http://www.gneuss.com)

Fakuma: Booth A6-6501

# Benchmark in Standard Compounds

The plastics specialists at LEHVOSS Compounds bring standards into series production at low cost. From a huge product portfolio, decades of expertise and a lot of industry experience, standard compounds have been developed in Hamburg that are clearly ahead of the market in terms of performance and price.

"LEHVOSS is known as a border crosser in the area of what is technically feasible. For us, that also means clearly assuming cost leadership in important segments - with unrestricted performance," says Dr. Thomas Oehmichen, Managing Director and Partner at LEHVOSS.

Cost efficiency is the key competitive factor for modern industry. The current economic conditions have reinforced this trend again: only those who manage to strike a balance between top performance and costs will survive in this challenging environment in the long term. For industries such as automotive, consumer or E&E, processability and uncompromising performance are important in addition to competitive material prices. Developing compounds to the point is the clear strength of LEHVOSS Compounds.

In addition to the many successes in the 40-year history of the world's unique high-performance compounds, LEHVOSS Compounds has been active with selected customers for several months with the new STANDARD portfolio and in this short time has already realized several projects that are ready for the market.

LEHVOSS Compounds invites customers and interested trade fair visitors to get to know the proven high-performance products as well as the new STANDARDS at the trade fair booth using selected application examples:

**LUVOCOM:** Compounds that are specifically developed to meet customer requirements, in particular outstanding performance properties. They are used in demanding industries such as automotive, electronics or medical technology.

**LUVOTECH:** Proven standard products such as PA66/PPA, PP CF or LCP compounds from LEHVOSS are characterized by cost-effective prices, fast delivery times and outstanding personal service. Direct access to personal contacts is part of the service.

**LUVOTECH eco:** PA6, PA66, PBT, PC/ABS, PPS GF, LCP and PEEK alternatives with different recycled content. LUVOTECH eco compounds are characterized by the highest level of property consistency and high performance, are attractively priced and at the same time sustainable.

**LUVOCOM LFT:** LEHVOSS offers cost-optimized alternatives for commercially available long-fiber materials based on PA66, PA66/6 and PA66-6I/X. In addition, other technical LFT compounds are available, e.g. based on PA410, PA11. In addition to the commercially available LFT with glass fiber reinforcement, LEHVOSS Compounds brings the existing practical expertise to the portfolio of carbon fiber reinforced LFT. Special modifi-



Material endurance test as part of the Xtreme Tech Expedition. Carbon fiber reinforced thermoplastics from the LUVOCOM XCF product line are revolutionizing bicycle frame construction. Frames manufactured by V Frames

cations, such as wear and friction optimization, coloring or flame retardancy are also available.

At booth, LEHVOSS Compounds will demonstrate inspiring exhibits that reflect creativity in finding technical solutions combined with high cost-efficiency.

Lehmann&Voss&Co. KG  
[www.lehvooss.de/compounds](http://www.lehvooss.de/compounds)  
**Fakuma: Booth B1-1106**

## Smart control boosts efficiency





**Fakuma: Hall A1, A1-1005**

- Smart Control for optimized operation
- Efficient, energy-saving plastics recycling
- Good ratio of throughput to energy consumption





[www.hellweg-granulators.com/en/](http://www.hellweg-granulators.com/en/)

# Forward-Looking Digital Solutions for the Extrusion Industry

Leistriz will again showcase its competence for innovations and digital solutions at this year's Fakuma. True to its motto "INSPIRE | INNOVATE | INTEGRATE", the company will be presenting how automation is becoming a reality through the digital control of machines, while also offering answers to the shortage of skilled workers. Visitors will have the opportunity to experience live demonstrations of the latest technologies, including LinXX digital control technology and the Customer Service Portal (CSP).

Leistriz' new LinXX control technology enables a comprehensive digital description of the entire extrusion process for extruders and extrusion systems. It facilitates the daily work of machine operators through a simple visualization of processes and parameters. The LinXX system can be used flexibly, from compact extruders to entire production lines, and offers a fully integrated solution for digital and future-proof control, monitoring and maintenance of extruders of any size.

*Leistriz LinXX – Digital control technology for extruders and extrusion systems*



Outstanding features of the Leistriz LinXX Human Machine Interface (HMI) include an overview of the entire extrusion line, quick access to all main units, intuitive operating structure, customized configuration of the dashboard, storage of recipes for reproducibility as well as an OPC-UA interface and web-based control technology for seamless digital integration.

"Introducing LinXX, we are revolutionizing the way extrusion processes are controlled and monitored," says Daniel Nagl, Managing Director of Leistriz Extrusionstechnik. "Our goal is to increase efficiency, achieve reproducible results and drastically reduce errors. At the same time, we offer our customers an answer to the current shortage of skilled workers by facilitating the daily work of machine operators and enabling even less experienced operators to achieve optimum results."

Another highlight at Fakuma is Leistriz's LinXX Customer Service Portal (CSP). The CSP is a user-friendly online portal that provides customers and Leistriz employees with a comprehensive overview of their Leistriz extruders, auxiliary units and extrusion lines. Customers can see relevant machine information such as machine number, operating hours, current warning messages and machine documentation clearly presented. The portal also contains maintenance schedules to ensure machine availability and a basic knowledge database with information on maintenance

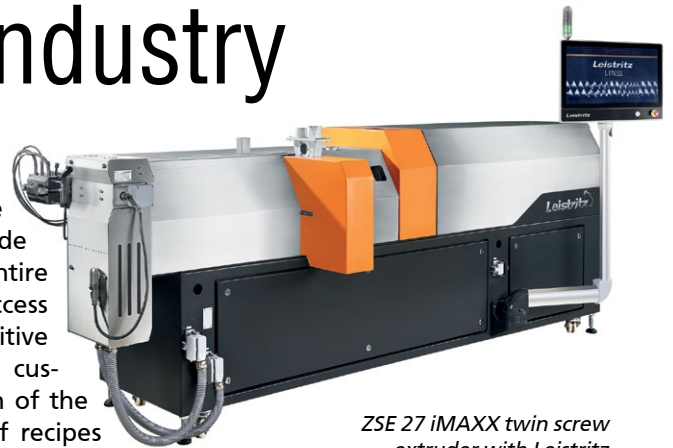

*ZSE 27 iMAXX twin screw extruder with Leistriz LinXX control technology*

issues and extruder components. Customers can also identify and order spare parts quickly and easily via the Leistriz CSP. Particular attention has been paid to data security: The customer retains full control at all times on the integration of the machines into the Internet and on what information is transmitted.

"The Leistriz LinXX Customer Service Portal is an important addition to our technological solutions," explains Daniel Nagl, adding: "It enables our customers to communicate easily with our service team, quickly identify spare parts and plan maintenance work efficiently. At the same time, we attach great importance to the security of the data and give our customers sovereignty over the scope of data transfer."

Leistriz Extrusionstechnik  
[www.extruders.leistriz.com](http://www.extruders.leistriz.com)  
**Fakuma: Booth A6-6302**



*Leistriz LinXX HMI – flat screen design, intelligent control technology, easy installation and maintenance*

# ISEC evo also Keeps Composite Materials in the Loop

With the ISEC evo plastic pelletising system, PURE LOOP offers a high-performance recycling machine for processing a wide range of production waste. In tests with thermoplastic composites and glass fibre waste, PURE LOOP has already been able to confirm the high quality of the recycled pellets for return to injection moulding production several times.

Thanks to the ISEC evo, production scrap from various plastics, such as polystyrene, polycarbonate, polypropylene and polyamide, can be gently processed into high-quality recycled pellets. "Our integrated shredder extruder combination is the perfect solution for injection moulders who want to return their production waste to the production cycle in high quality. This is a crucial aspect for a sustainable, cost-efficient and resource-saving production," says Manfred Dobersberger, Managing Director of PURE LOOP.

Disposing of scrap parts and sprues from the injection moulding process is associated with work and sometimes high costs. Feeding

them back to the production process therefore offers economic benefits for injection moulders. "Our ISEC evo sets new standards in the recycling of injection moulded parts by ensuring a consistently high quality of recycled pellets," explains Dobersberger. In contrast to grinding processes, only minimal changes in the Melt Flow Index (MFI) occur during repelletising and there is no dust, which promotes the formation of soot particles. The regranulate has the same shape and melt performance as virgin material, which makes it easier to feed back into the injection moulding machine.

The system, which is equipped with a melt filter, also copes excellently with challenging materials of different sizes and shapes. The use of high-quality carbide knives, a protected rotor, special treatment of the screw flights and other measures increase the wear resistance of the system. As a result, composite materials or glass fibres can also be optimally processed. "During tests in August at our R&D Center in Ans-

*The integrated shredder extruder combination ISEC evo converts production waste into plastic regranulate that can be fed back into the production cycle*



*Manfred Dobersberger, Managing Director of PURE LOOP, emphasises in the run-up to Fakuma: "Our ISEC evo is the perfect solution for injection moulders who want to return their production waste to the production cycle in high quality."*

felden, the ISEC evo was once again able to prove its high performance," says Dobersberger. During the production of glass fibre-reinforced fabric, scrap is produced from the non-crimp fabric or also residual spools. The 100 percent glass fibres were fed into the recycling process without pre-shredding and compounded with polypropylene or other polymers. "In the tests, the recycled pellets produced showed higher mechanical properties than the virgin material from well-known manufacturers," emphasises Dobersberger.

The PURE LOOP team will be available for discussions at the Fakuma. Dobersberger invites all visitors: "We have a high level of problem-solving expertise and are happy to discuss even the most challenging issues. Please come and talk to us at the Fakuma."

**PURE LOOP GesmbH**  
 ➔ [www.pureloop.at](http://www.pureloop.at)  
**Fakuma: Booth A6-6314**

*The latest tests with an ISEC evo with 100 percent glass fibres were a complete success! The mechanical properties of the regranulates exceed those of virgin material from well-known manufacturers*



# High-Efficiency Technologies For Processing And Recycling Plastics

At Fakuma 2024 Coperion and Herbold Meckesheim will jointly present numerous product and process solutions that make both compounding and recycling of plastics markedly more efficient and that consistently achieve high product quality.

Coperion and Herbold Meckesheim will demonstrate their expertise in realizing entire systems using virtual animation: Both a complete compounding plant as well as an entire system for recycling plastic will be available to view. The processes involved can be experienced digitally with the aid of simulations, and visitors will be able to peer into individual key components and their functions.

Moreover, rotors from Herbold Meckesheim granulators will be on display in various sizes and for a myriad of applications. Within the rotor concept, the cutting geometry is the primary reason for the high efficiency of Herbold Meckesheim's rotors.

## Efficient plants for recycling a myriad of plastics

Along with individual components, Coperion and Herbold Meckesheim deliver entire systems for plastics recycling. From mechanical processing – shredding, washing, separating, drying and agglomerating of plastics – to bulk material handling as well as feeding and extrusion all the way to compounding and pel-

*Coperion and Herbold Meckesheim realize entire systems for recycling all sorts of plastic with very high end product quality (Photo: Coperion, Stuttgart, Germany)*



*Herbold Meckesheim's granulators are especially outstanding for their high-efficiency rotor cutting geometry (Photo: Herbold Meckesheim, Meckesheim, Germany)*

letizing, such plants cover the entire plastics reclamation process chain.

Currently, Coperion and Herbold Meckesheim are realizing an entire bottle-to-bottle recycling system for Indian preform and plastic packaging manufacturer Magpet Polymer Pvt Ltd. This plant handles every process step from mechanical processing of used PET bottles to discharging high-quality PET granulate, using a ZSK twin screw extruder with fully attuned peripherals to meet every need. Magpet awarded the contract for this PET recycling plant to Coperion and Herbold Meckesheim as they have optimally coordinated their technologies and realized efficient plastic recycling solutions that

consistently and reliably deliver high PET recycle quality.

## Recycling Test Center

In its fully equipped Test Centers, Coperion and Herbold Meckesheim offer customers the ability to test an enormous variety of plastic recycling processes and technologies under actual production conditions even before investing. At Herbold Meckesheim, within its 800 m2 facility in Meckesheim, Germany, there is a complete washing line for cold and hot washing as well as every size reduction solution from shredders and granulators to pulverizers or plastic compactors for densification, all at the customers' disposal. In 2023, Coperion launched the operation of the Recycling Innovation Center in Weingarten, Germany with state-of-the-art, individually

*The latest version Coperion ZSK 18 MEGALab laboratory extruder combines proven ZSK series functions with new developments that enable flexible and intuitive handling (Photo: Coperion, Stuttgart, Germany)*

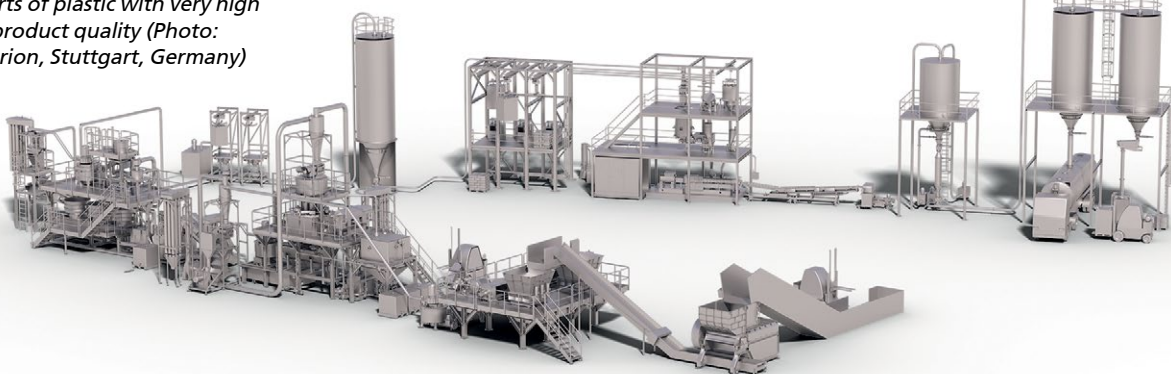
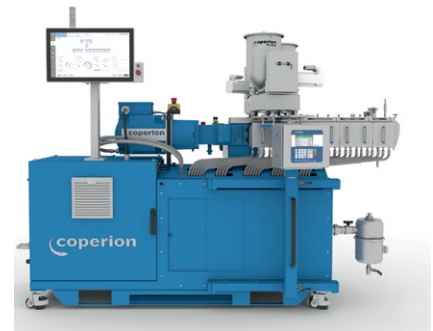

configurable recycling plants where recyclate can be conveyed, fed, extruded, compounded, pelletized and deodorized. Both Test Centers complement each other perfectly to simulate and test the recycling of plastics. During the Recycling Days2 2024 on November 6 and 7, Herbold Meckesheim and Coperion are offering the opportunity to see the new Recycling Innovation Center in person. At this symposium, industry experts will highlight currently available technology and process solutions that make plastics recycling economically more appealing and versatile to use. Additionally, the entire recycling process will be on view in live presentations.

**Smart solutions for classic compounding tasks**

Along with recycling, at this year’s Fakuma, Coperion will present versatile and efficient uses of its ZSK and STS twin screw extruders as well as its feeding and conveying technologies for classic compounding tasks. With continuous research and development, Coperion continues to pursue its goal of setting new standards in machine and plant engineering for processing technology. For example, at the beginning of this year, Coperion introduced a reworked version of the ZSK 18 MEGAlab laboratory extruder. With its optimized design, the ZSK MEGAlab now offers even more flexibility and

*The gravimetric ProRate PLUS single and twin screw feeders are very robustly constructed and stand out with their good price-to-performance ratio (Photo: Coperion K-Tron, Niederlenz, Switzerland)*



safety in handling. Using the newly developed patent-pending feeding platform, up to four feeders can be placed over the extruder’s intake barrel with great variability, allowing ingredients to be added very flexibly into the compounding process.

Likewise, Coperion’s ProRate PLUS feeder line features new developments. With the ProRate™ PLUS-MT twin screw extruder and the new ProFlow™ bulk solid activator, an efficient feeding solution for

powder additives is now available. Continuous-operation gravimetric ProRate PLUS feeders stand out with a good price-to-performance ratio and short delivery times.

**Coperion**  
[www.coperion.com](http://www.coperion.com)  
**Herbold Meckesheim**  
[www.herbold.com](http://www.herbold.com)  
**Fakuma: Booth A6-6312**

**SIKORA**  
 Technology To Perfection

**SIKORA X-RAY 6000 PRO**

**X-RAY 6000 PRO – 360° measurement of hoses & tubes**

- Measuring ranges from Ø 0.65 to 270 mm
- Min. wall thickness > 0.3 mm
- Up to three different layers
- Automatic control of each layer to minimum wall thickness
- “One Button Operation” – no calibration, no parameters
- Measurement of corrugated pipes with „C-PIPE” version
- Continuous quality monitoring and documentation

QR code with Video link

[www.sikora.net/xray6000](http://www.sikora.net/xray6000)

# Auxiliary Equipment and Automation

**F**akuma is an important event for the plastics processors always focused on market developments and looking for new exclusive and competitive solutions characterized by an advanced level of technology and performance. Moreover, the Italian company based in Massanzago (Padua) leader in the production of automations for the plastics processing industry, will be present with several novelties.

Moretto considers fundamental to invest in innovation, research and testing activities to design and develop future-oriented solutions. The laboratory of the R&D department consists in several state-of-the-art instruments such as rheometers for viscosity control, a gas chromatograph for acetaldehyde control, a DSC for crystallinity control, professional sound level meter, fine dust measurement, infrared cameras, professional high-speed cameras (10,000 frames per second), temperature and airflow control, chilled mirror hygrometer for humidity measurement, anemometers and portable testing tools.

In addition, Leonardo, the Supercomputer with a mathematical simulation software capable of calculations of:

- Load-bearing structures such as mezzanines, mechanical strength;
- Thermodynamics for controlling heat distribution;

*DSC for crystallinity control*



*Rheometer for viscosity control*

- Fluid dynamics with analysis of air and fluid flows;
- Electromagnetism for electromagnetic energy analysis;
- Sound analysis, precision of acoustic impact on devices.

## Five novelties

Moretto involves this high technological equipment in the design of its automations. They have been essential in the product development of Flowmatik, Kruse Control, X Dryer, X Comb, X MAX, Kasko, and au-

*Gas chromatograph for acetaldehyde control*



*DGM Gravix 20*

tomatic One Wire 6. The challenge goes on with new products such as Gravix DGM 20, Kasko Filterless, X Comb 12, 6050 Hyper Cut grinder and Navigator 9001.

**Gravix**, high performance doser that elevates precision in micro-dosing: digital electronics, double eyelid shutter device, self-learning for a compact doser with great benefits for customers.

**Kasko Filterless**, a system suitable for plastic granules and/or regrind conveying with the same performance as a filtered system, while avoiding maintenance and filter cleaning.

**X Comb 12**, the smallest dryer in the market has a constant performance, -50 °C Dew Point, and very







Interconnected control room for remote assistance

low energy consumption. Moretto offers the smallest dryer with OTX (Original Thermal eXchanger) hopper and X MAX, the biggest dryer capable of 20,000 kg per hour suitable for large productions, extrusion and/or compounding guaranteeing constant efficiency. Moretto dryers range consists of 49 models offering a wide and complete product range in dehumidification. X Comb is the latest of 16 patents in drying.

**GR 6050 Hyper Cut**, a newly designed, low speed grinder will be introduced in the market. A starve

feeding granulator suitable for grinding waste pieces, sprues and blown parts with 15 movable blades. The engine power is transferred on a single mobile blade and three standard fixed blades. The 160-degree grid increases the GR productivity while reducing consumptions. GR 6050 Hyper Cut is 5 ready and second to none.

**Navigator 9001**, a control system developed by Contrex, a company of Moretto group, for blown film production. It is 5.0 ready allowing film production

to start automatically in just 5 minutes compared to 25-30 minutes required by conventional automations available on the market. Navigator 9001 ensures double-digit energy savings for film production.

**MOWIS**, a proprietary supervision platform that simplifies the management of complex systems and provides an immediate view of the plant status for maximum benefits in terms of productivity, traceability, elimination of human error, and optimization of production costs.

To enhance the after-sales service, an interconnected control room ensures remote assistance of the more than 2,200,000 units already installed worldwide. With 115,000 machines produced each year, Moretto is a short supply chain company that manufactures more than 75% of its components in-house in adherence to Smart Factory 4.0 criteria.

This is only a taste of what's to come at Fakuma.

Moretto

➔ [www.moretto.com](http://www.moretto.com)

Fakuma: Booth B3-3208

X Comb Installation



ERGE Elektrowärmetechnik - Franz Messer GmbH  
 91220 Schnaittach - Hersbrucker Straße 29-31  
 Tel. +49/9153/921-0 Fax +49/9153/921-117  
[www.erge-elektrowaermetechnik.de](http://www.erge-elektrowaermetechnik.de)  
 mail: [verkauf@erge-elektrowaermetechnik.de](mailto:verkauf@erge-elektrowaermetechnik.de)

HEIZEN  
HEATING

TROCKNEN  
DRYING

REGELN  
CONTROLLING

Visit us:  
Hall A6,  
Stand 6301

ELEKTROWÄRMETECHNIK FRANZ MESSER GMBH

# Sustainable Solutions for Mixing, Foaming and Cooling

At this year's Fakuma, Promix Solutions will exhibit key components for the production of light foams, static mixers, melt coolers and inline viscometers for real-time process control, at the new location in Hall A6, Stand 6108.

In extrusion, material accounts for 80% of the CO<sub>2</sub> footprint. This is where Promix comes in: With Microcell Technology, a microcellular foam structure is created in the polymer by adding environmentally friendly atmospheric gases. This results in a 20 to 50% reduction in product weight, leading to significant savings in raw materials. Not only does this lower production costs, but it also benefits the environment.

Promix Microcell Technology is suitable for films, sheets, foam core and corrugated pipes as well as profiles, cable sheathing, blow molds and blown films. At Fakuma, Promix will be showcasing relevant key components and providing information about the possibilities within the specific fields of application. More than 300 industrial references are now in operation and various machine manufacturers are successfully integrating the

*Foamed sheet produced with Microcell Technology from Promix*

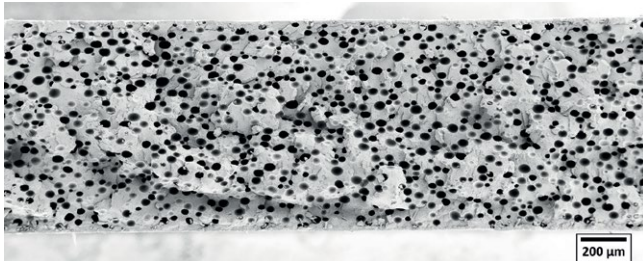

*Promix Microcell Technology on an extrusion line for packaging films*



*The inline viscometer "Visco-P" measures the actual viscosity of the melt under process conditions in real time (Pictures: Promix Solutions AG)*

technology into their lines. Promix Microcell Technology can be used for almost all raw materials, such as PP, PE, PET, TPE, TPU, PA, rigid & soft PVC and biopolymers. The technology is available for new extrusion lines and as a retrofit solution for existing lines.

## Monitoring raw material quality and process conditions in real time

The increased use of recycled material and raw materials from different sources makes it more and more difficult to keep extrusion processes under control. The "Visco-P" inline viscometer measures the actual viscosity under processing conditions and in real time directly in the melt stream, without any bypass or material loss. The measuring module, which is tailored to the application, homogenizes the melt without the risk of clogging, deposits or decomposition. The Visco-P is therefore ideal for recyclates as well as filled and shear-sensitive materials.

Trend evaluations and reporting tools enable the measurement results to be recorded with statistical analysis. User-selectable upper and lower limits for the viscosity trigger an alarm and inform the operator of current deviations from the target value. This means that corrective measures can be initiated immediately to ensure a high level of quality.

The Visco-P inline viscometer is compatible with all common extruder types and almost all polymers and can be retrofitted to existing systems.

# Plasma Treatment

**F**errarini & Benelli, the Italian company (based in Romanengo, province of Cremona), is specialised in designing and manufacturing surface treatment systems with 60 years of experience. The company's plasma treatment is used worldwide to activate plastic substrates, making them more receptive to inks, glues and coatings to ensure excellent printing, varnishing and gluing.

The plasma discharge is directed towards the substrate to treat through one or more discharge

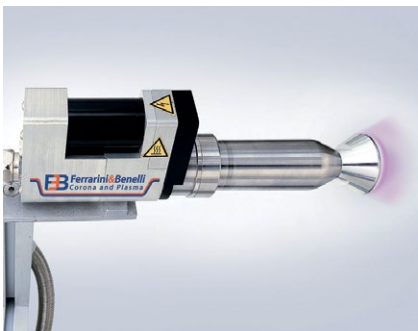

nozzles. The discharge nozzles differ in type and quantity depending on the application, type of substrate and area width to act upon. The surface tension achieved is very high owing to the targeted discharge.

Main applications

- Folder-gluer lines, to improve adhesion when manufacturing plastics boxes
- Pipes and pex pipes to improve the quality of ink-jet marking
- Electrical and special cables to optimise coding
- Metal substrates, to rid them of the oil residues from lamination
- Components used in electrical boards and printed circuits

Plasma treatment is a practical and efficient solution, which may replace chemical treatments and primers, has a reduced energy consumption, increases productivity



and does not release pollutants into the atmosphere.

The Ferrarini & Benelli team help customers choose the best solution and integrate it flawlessly into any production line:

- In Air Plasma is available with 1-2-3-4 nozzles (the treating width of each nozzle is 10 mm)
- In Air Plasma Spark is available with 1 or 2 nozzles (each has a treating width of 40 mm)
- In Air Plasma XL is equipped with two special interchangeable nozzles (one of 25 mm and the other of 70 mm).

Ferrarini & Benelli  
 ➔ [www.ferben.com](http://www.ferben.com)  
 Fakuma: Booth A7-7404

# Material Solutions for Thermal Management of EVs, Recycling and 3D Printing

**J**apanese technology company Asahi Kasei will exhibit its broad range of diversified material solutions at Fakuma 2024 in Friedrichshafen, Germany. Highlights include polymer solutions for thermal

management applications in EVs, a novel thermoplastic elastomer for improved recyclability of automotive interior parts, and a cellulose nanofiber composite for high-performance 3D printing.

Asahi Kasei will present its materials and solutions in three different areas: "Compact & Safe EV Batteries", "Improved Connectivity & Lightweighting", and "Sustainable Material Life Cycle".

At the battery island, the company will showcase the modified polyphenylene ether (mPPE) XYRON™. Featuring a high non-halogenic flame retardance and the lowest ion elution properties, this material is suitable for thermal management applications in EV batteries. At Fakuma, Asahi Kasei will also show multilayer cooling pipes that do not require an adhesive layer. These pipes are made of a composite of the company's LEONA™ PA on the outside, and XYRON™ on the inside. This pipe offers excellent bending properties, hydrolysis resistance and low ion elution properties.

To meet the increasing demand for materials that boost the efficiency of 5G applications, Asahi Kasei is currently introducing new grades of its all-round material XYRON™ to the European and North American markets. The combination of PPE with other polymers such as polyphenylene sulfide (PPS) or polystyrene (PS) allows this family of high-performance compounds to feature low dielectric properties and a high non-halogenic flame retardance. Together with the Tokyo Institute of Technology, the company has created a prototype resin antenna utilizing a new XYRON™ grade. This grade offers high heat resistance and a stable, low linear expansion coefficient over a wide temperature range. This makes this material ideal for plating-on-plastics applications and metal replacement in components that require precision – like slotted waveguide array antennas.

From automotive head-up displays to head-mounted displays and smart glasses, the requirements towards weight and design of optical devices have been steadily increasing in recent years. The transparent polymer AZP™ features an almost zero birefringence and is overcoming the challenges of conventional transparent polymers in applications with polarizing light. Its superior processability compared to glass enables the large-scale production of injection-molded optical components that



*Asahi Kasei booth at Fakuma*

fulfill the demanding customer requirements.

Achieving a good balance between sustainability and functionality without sacrificing cost-competitiveness is a major issue for car manufacturers. To tackle this challenge, Asahi Kasei is currently developing a tailor designed thermoplastic styrene block copolymer (SEBS) grade for automotive interior surfaces, which require good haptics and soft touch. Conventional approaches use different materials and production technologies for skin, foam and core layers in automotive instrument panels, door panels, armrests or center consoles.

The connection to the polypropylene (PP)-based core layer is possible in the same or separate injection molding step. The strong chemical bonding between all layers eliminates the need for additional adhesive layers. Asahi Kasei's new SEBS contributes to reducing the total number of materials, simplifying the manufacturing process, and improving the recyclability of interior components.

Asahi Kasei will display a bio-based and biodegradable cellulose nano fiber (CNF). This material is made from cotton linter and features a high heat resistance and network-forming ability. CNF-reinforced polyamide shows a thixotropic behavior, making it highly

suitable for 3D printing applications for easy printing, dimensional accuracy, smooth appearance, and mechanical performance. Furthermore, CNF has superior material recyclability compared to glass fibers.

The company will also present its comprehensive solutions for establishing a sustainable life cycle for PA66. In the field of chemical recycling for polyamide 66, the company works together with Japanese partner company Microwave Chemical. The process utilizes microwaves to depolymerize automotive airbags and other PA66 parts and directly obtain the monomers hexamethylenediamine (HMD) and adipic acid (ADA), which is expected to be accomplished at high yield with low energy consumption. The monomers obtained can then be used to manufacture new PA66.

In parallel, Asahi Kasei will introduce its development of a new solvent-based recycling process for the first time in Europe. By applying this dissolution recycling, high quality PA66 can be obtained from process scraps and used PCR materials, like airbags.

Asahi Kasei Corporation  
 ➔ <https://fakuma.asahi-kasei.eu/>  
**Fakuma: Booth B5-5319**

# Focus on Innovative Technologies and New Products

FEDDEM is once again exhibiting at this year's Faku-ma and will be presenting its latest developments. In addition to its tried-and-tested extruder models, the company will be focussing on the expansion of its portfolio, new developments in peripheral technology and pioneering augmented reality applications.

FEDDEM will be presenting the latest model of the FED 26 MTS twin-screw extruder with additional aggregates (see picture 1) at its stand, as a production machine for small quantities or for use as a pilot plant extruder. The exhibit is equipped with the following accessories:

- Extruder with 32 L/D and a 10 L/D extension module, 34 kW installed drive power and max. screw speed of 1200 rpm.
- FSB side feeder
- FSV vacuum side degassing unit
- FSK extrusion head with FEDDEM's patented sheet die plate

In addition to the FED 26 MTS, FEDDEM is expanding its portfolio with the new FED 18 MTS extruder. This compact extruder is more than just a new size. It is specially designed to meet the requirements of a laboratory extruder and thus offers customers an optimum solution for formulation and product development in the well-known FEDDEM quality.

"The FED 18 MTS represents our continuous further development in the field of extrusion technology. With its modular design, it is designed to meet the special requirements of our customers in terms of flexibility and user-friendliness and to help them optimise their production processes in an efficient and resource-saving manner," says David Constroffer, Head of Engineering at FEDDEM.

Another innovation on the stand is the FEDDEM Automatic AirBlade (see pictures 2 and 3). This product innovation was developed to minimise the frequent problem of beard formation in twin-screw extrusion. Bearding occurs when thermoplastic material or filler accumulates at the die outlet of the extruder and hardens. In the case of

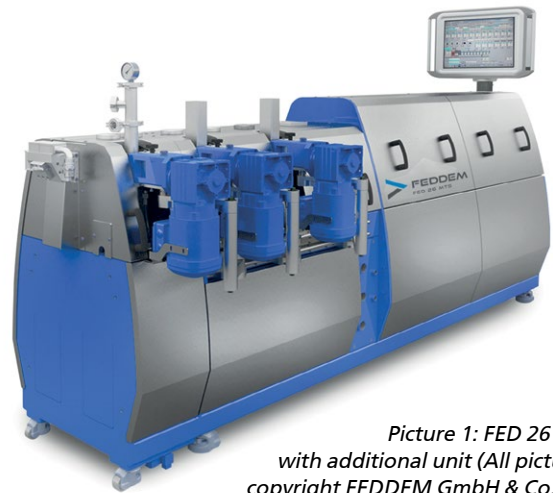

Picture 1: FED 26 MTS with additional unit (All pictures: copyright FEDDEM GmbH & Co. KG)

complex compounds with a high filler content, this can lead to strand breaks without suitable countermeasures, which can significantly impair both productivity and the throughput rate. In addition, residues that adhere to the polymer strand can have a significant impact on the optical and mechanical quality of the end product.

The FAA offers an efficient solution to this problem by removing residues with a targeted stream of hot air. "The FAA was developed in close collaboration with one of our customers and tested under real production conditions," reports David Constroffer. "This product innovation effectively minimises the negative effects of product residues at the nozzle outlet and thus ensures improved productivity and product quality."

According to the manufacturer, a special feature of the FAA is the patent-pending deflection mechanism, which sets it apart from conventional solutions. This mechanism ensures that the slot die is automatically retracted from the operator's working area as soon as a strand breakage occurs. This function is designed not only to protect the operator, but also to ensure a smooth production process by minimising potential disruptions in the process. "With this innovative deflection mechanism, we offer a solution that significantly improves both safety and efficiency," emphasises David

Constroffer. "The FAA represents a significant improvement over conventional methods and fulfils the highest requirements of our customers."

In addition to the trade fair highlights, FEDDEM is pleased to announce the commissioning of its new pilot plant line. In the technical centre, customers have the opportunity to carry out tests on a wear-protected FED 43 MTS

Picture 2 and 3: The new FEDDEM Automatic AirBlade (FAA)





Picture 4: The OCULAVIS share system for remote assistance will be on show at Fakuma

twin-screw extruder. According to the manufacturer, the process length of the extruder can be flexibly adjusted from 32 L/D to 42 L/D and 52 L/D, so that a wide range of plastics – from standard to high-performance plastics – can be processed. The system also features additional units such as the FSB side feed, FSB V side feed

with vacuum support and FSV vacuum side degassing. With this new offering, the machine manufacturer provides its customers with extended options for process optimisation and the development of new materials. Customers can also test the latest product innovations from FEDDEM in the technical centre.

According to the machine manufacturer, another highlight at the trade fair stand will be the demonstration of remote assistance using augmented reality and the extended electronic provision of information.

"We will be demonstrating live the adaptation of the OCULAVIS Share system (see picture 4) on our products," explains Lars Mansfeld, Team Leader Technical Service. "In addition to real-time support for service work via the remote maintenance system (Remote Guidance), the system is also suitable for "step-by-step" guidance (Self Guidance) via the coupling of imaging processes with stored information - without being in direct contact with one of our experts".

FEDDEM GmbH & Co. KG

➔ [www.feddem.com](http://www.feddem.com)

Fakuma: Booth A6-6217

## 'Recycling & Defossilization'

**F**KuR Kunststoff, a leading compounder of bioplastics and recyclates, will showcase its latest developments in sustainable plastics at the Fakuma.

"Plastic solutions that reduce the CO2 footprint, sensitive handling of diminishing resources, and sustainable packaging made from recyclable, circular materials will also be the focal themes of our customers at this year's Fachpack," asserts Niklas Voß, Deputy Sales Manager at FKUR.

"Carbon neutrality" and "reducing plastic waste" are the major issues of our time. Especially in light of regulatory changes, such as the PPWR, and consumer demand for greater sustainability, above all packaging materials and components will need to be reimagined. FKUR offers a globally unique range of various plastics from a single source," emphasizes Niklas Voß.

At its booth, FKUR presents a wide range of sustainable plastics for recyclable packaging. The solutions range from biobased bioplastics to recycled plastics and hybrid compounds (bio + recycled).

Under the brand name Macolen®, FKUR showcases high-quality PP recyclate compounds sourced from post-consumer and pre-consumer materials. These modified recyclates match virgin plastics in odor and technical properties. Customers can choose from various injection molding and profile extrusion grades. In addition to non-reinforced types, FKUR also offers two variants with talcum reinforcement (20% + 40%). Macolen® compounds are suitable for diverse non-food applications.

Terralene® rPP is a product family of hybrid compounds based on polypropylene (PP), combining the ecological benefits of recyclates and biobased materials with excellent recyclability. Depending on the product grade, recyclate content ranges from 30% to 60%, sourced from post-consumer waste streams, with a biobased content of up to 33%. The drop-in product range of Terralene® rPP, known for its good flowability and natural granule color, is currently limited to non-food applications.



(© FKUR Kunststoff GmbH 2024)

Especially in food packaging, there are still hurdles and regulatory uncertainties regarding the use of recyclates. For manufacturers looking to make their products more sustainable today, FKUR's bio-based, highly recyclable drop-in bioplastics from the Terralene® family are the ideal choice. Terralene® biocompounds are based on polyethylene (PE) from renewable resources. All Terralene® granules are 100% recyclable and can be processed through injection molding, blow molding, and film extrusion.

FKUR Group

➔ [www.fkur.com](http://www.fkur.com)

Fakuma: Booth B4-4405

# Latest Developments in Advanced Mold Temperature Control Units and Adiabatic Cooling Solutions

**F**rigel Group will participate in Fakuma 2024, presenting the latest process cooling solutions, designed especially for the following Plastics fields: automotive, packaging, medical, household and technical molding.

Frigel is a Global Solutions Provider for cooling and temperature control applications, with more than 10.000 customers worldwide. The company's innovation and expertise offer unique systems, designed to match the specific needs of each industrial process.

**The innovative solutions are focused on:**

- Maximizing productivity through highly innovative mold cooling technologies;

- Reducing overall operating costs, through significant energy and water savings;

- Highest sustainability standards, with the lowest environmental footprint in the market.

#### **Innovations:**

- New Turbogel B4: a new generation of Mold Temperature Control Units, specifically designed for cycle-time reduction for all injection molding and packaging applications achieving up to 40% increased productivity

- New Microgel™ RSY: Unique Mold temperature Unit with patented SYNCRO Variotherm Technology, provides unprecedented increase in productivity of high-quality technical molding parts - up to 60%

- Ecodry Adiabatic Cooler 4DK: centralized closed-circuit adiabatic cooling systems designed to replace the old cooling tower technology

- 3PR 4.0 control system: complete real-time control of the entire cooling system (parameters, functions, alarms, etc.)

- Thermogel TDK Series: High precision Single Zone pressurized water TCUs

- A wide range of Microgel RSM/RSD provides an optimized mechanical design, increased reliability and a wide range of options. Powerful pumps and precise temperature control up to 90°C ensure long-term high performance and product quality improvement with minimal cycle cooling time.

#### **New TURBOGEL B4 Series**

Frigel launches for the first time in market history, a New Generation of Mold Temperature Control Units, specifically designed for cycle cooling time reduction. The advantages for the customer are easily understood, increased productivity and profitability of a single production cell, against an investment with an average payback time of few weeks.

The unprecedented performance of these units guarantees a significant reduction of the cycle time by increasing the heat transfer efficiency between recirculating water flow and mold cavities, thus drastically reducing the cooling time of the actual cycles, over traditional TCUs.

Turbogel "P" – for PACKAGING: This unique TCUs are designed for high performance mold cooling in low temperature applications, including packaging molding, closures and thin-walled containers, blow molding, and extrusion applications. Replacing the direct cooling from Central chillers, these units reduce cooling cycle time of processes running with chilled water by highly



increasing the heat transfer efficiency of the mold, obtaining productivity boost between 10 and 20%.

These units are available in single zone and dual zone configurations, including a high-performance booster pump per zone (with or without inverter), actuated modulating cooling valves and cooling capacities capable of servicing the highest throughputs.

#### **New MICROGEL™ SYNCRO RSY**

Frigel presents to the market MICROGEL SYNCRO RSY, the most innovative Mold temperature Control Unit featuring patented SYNCRO Variotherm Technology, integrated water-cooled chiller and double zone booster pumps.

The new machine-side unit, that revolutionizes the temperature control method for technical injection molding, allows for a drastic reduction of cycle time -up to 60%-, while maintaining the surface quality, dimensional characteristics and mechanical properties of the finished technical products.

FRIGEL FIRENZE S.p.A.

www.frigel.com

Fakuma: Booth A5-5123

# Ready to Stand Out? – *High-Quality Colour and Additive Concentrates*

Thanks to its comprehensive expertise and the continuous expansion of production capacities, AF-COLOR is one of the leading manufacturers of technically high-quality colour and additive concentrates. Special focus is placed on masterbatches for future-orientated and demanding applications. The highlights will be presented at this year's Fakuma 2024 in Friedrichshafen at the joint stand of the Feddersen Group.

Polyketone is currently enjoying increasing popularity. The engineering thermoplast has outstanding properties and also has a better CO<sub>2</sub> footprint compared to other polymers. The masterbatch manufacturer has developed an extensive polyketone-based masterbatch portfolio with a wide range of colours, which is approved in accordance with the regulatory guidelines of Regulation EU 10/2011.

The PK range has also been expanded to include a suitable cleaning granulate, especially for processing polyketone.



AF-COLOR has designed the range for a variety of engineering polymers. A comprehensive portfolio is available for applications with high processing temperatures.

A significant further development focuses on a blowing agent masterbatch customised for polyamides. The chemical blowing agents it contains ensure a density reduction of up to 40 %. As a result, CO<sub>2</sub> emissions are reduced and the signifi-

*The masterbatch manufacturer provides customised samples of its products (Photo credit AF-COLOR)*

cant weight and material savings are a decisive argument in favour of sustainability.

**AF-COLOR,**  
Branch of AKRO-PLASTIC GmbH  
➔ [www.af-color.com](http://www.af-color.com)  
**Fakuma: Booth B2-2213**

## Raw Materials

Multinational chemical distributor Nordmann will soon be presenting its diverse and innovative portfolio of additives, flame retardants and thermoplastic materials at the upcoming 2024 Fakuma trade show. In collaboration with its partners and co-exhibitors Repol/UBE, TotalEnergies Corbion and VOELPKER, Nordmann will be promoting a range of new solutions relating to sustainability and recycling.

As Nordmann Germany's Business Manager for Polymer Addi-

tives Christian Schur explains, "For years now, we've been building an extensive range of products that supports recycling. A great example are the multifunctional wax additives in the Plastic Recycling Series from our co-exhibitor VOELPKER that help support the production of especially high-quality recyclates. VOELPKER's CEVO® special waxes and additive formulations, too, are an additional portfolio highlight because of how they improve flow properties and

surface quality as well as filler and pigment dispersion. Our strategic supplier Kraton also offers innovative solutions for recyclers, processors and brand manufacturers. Kraton's CirKular+™ trademark, for example, was specially designed to support plastics upcycling and the modification of bioplastics."

Schur continues: "We've also been distributing a universal processing aid in Europe, bFI A 3745, from our new partner Polytives since April of this year. This pioneering mate-



rial allows for significant energy savings when it comes to standard processing methods like injection molding and extrusion, allowing for lower throughput times and increased output while making sure that finished polymers still have the

desired properties. The additives in the bFI family are therefore currently in high demand by manufacturers, and they are also incredibly attractive from a circular economy perspective. Additionally, our own product line of antioxidants and UV

stabilizers, NORANTOX®, can help support both new plastics and recycled materials.”

Nordmann, Rassmann GmbH  
[www.nordmann.global/de](http://www.nordmann.global/de)  
**Fakuma: B5-5214**

# Innovative and Sustainable Engineering Solutions for the Products of Tomorrow

**M**.TEC ENGINEERING GmbH presents cutting-edge engineering solutions for plastics technology and mechanical engineering, designed to address future challenges and seamlessly integrate into every stage of the development cycle across diverse industries.

As an independent engineering partner, M.TEC provides a comprehensive engineering service portfolio that covers the entire process along the value chain — from initial idea to design and series production.

Combining a highly qualified in-house simulation department with a creative, systematic approach, the engineers from Aachen high-tech region have been shaping the future of product development for more than three decades. M.TEC's goal is to develop sustainable and efficient solutions for products, processes, materials, circular concepts, logistics, and packaging that conserve resources and guarantee maximum competitive advantages. In addition to traditional engineering services, M.TEC uses advanced 3D printing technology to realize complex geometries and produce components faster and more efficiently. These innovative approaches contribute significantly to cost and risk minimization and enable flexible responses to individual customer requirements.

Using a self-developed AI-integrated development solution, M.TEC is revolutionizing the world



of plastics technology and mechanical engineering. This groundbreaking method delivers faster and more precise results, enabling more efficient production. Unlike conventional methods, the new technology simultaneously and parallelly considers various physical areas. The result is maximum quality, accuracy, stability, and process reliability. Development risks and resources are drastically reduced, and production is made more cost-efficient. The integration of AI into M.TEC's engineering process significantly shortens time-to-market while considering sustainability aspects, allowing for efficient development of small series and prototypes. This powerful technology has already proven itself with renowned corporations like BMW and leading companies in

*Innovative AI-integrated systematics from M.TEC ENGINEERING  
 (©ipohba/stock.adobe.com)*

the medical field and other industries worldwide.

With the new B2B solution, M.TEC takes an important step towards becoming a technology leader, making production processes more profitable across industries. At FAKUMA 2024, visitors can discover the new possibilities M.TEC's innovative engineering is making feasible.

All application examples and project results can be viewed in detail at booth 2213 within the Feddersen group joint stand in hall B2.

M.TEC ENGINEERING GmbH  
 ► [www.mtec-engineering.com](http://www.mtec-engineering.com)  
**Fakuma: Booth B2-2213**

# Double Filtration in Plastics Recycling – *More Than a Trend*

*In the face of growing environmental concerns and regulatory pressures, the plastics industry is undergoing a significant transformation. Central to this change is the adoption of more advanced recycling technologies, particularly double filtration systems. As the demand for high-quality recycled plastics intensifies, double filtration is emerging as a critical process that ensures the purity and consistency of recycled materials, making them suitable for a wider range of applications.*

The global plastic waste crisis has reached alarming levels, with millions of tons of plastic waste generated annually. Much of this waste ends up in landfills or the environment, where it can take centuries to decompose. Recycling offers a solution, but traditional recycling processes often struggle to produce materials of sufficient quality for reuse in high-value applications. Contaminants such as dirt, oils, and non-plastic materials can compromise the integrity of recycled plastics, limiting their use and market value.

The increasing demand for high-quality recycled plastics, driven by both consumer preferences and regulatory mandates, is leading to broader adoption of double filtration systems in recycling facilities. Companies across the plastics value chain are investing in advanced recycling technologies to enhance the quality of their output and to stay competitive in a rapidly evolving market.

For example, in Europe, where stringent regulations like the Eu-



Fimic booth at NPE2024

ropean Union's Single-Use Plastics Directive are driving the need for more sustainable plastic solutions, double filtration is becoming a standard practice in many recycling plants. In the United States, similar trends are emerging as states and municipalities enact laws aimed at reducing plastic waste and increasing recycling rates.

In response to these challenges, the industry is increasingly turning to double filtration techniques. This process involves passing plastic materials through two successive filtration stages during recycling, significantly improving the purity and quality of the end product.

This second filtration stage employs a finer filter or an additional specialized filtration system designed to remove even smaller particles and contaminants that may have passed through the first filter.

The result is a much purer, higher-quality recycled plastic that can meet the stringent requirements of various industries, including automotive, packaging, and consumer goods.

Despite its advantages, double filtration is not without challenges. The process requires significant investment in equipment and technology, which can be a barrier for



smaller recycling operations. Additionally, the increased complexity of the recycling process can lead to higher operational costs.

However, FIMIC has a proven double filtration technology that allows to process heavily contaminated plastic waste streams, with only one machine and two filtration steps: ERA melt filter.

With the ERA filter, some very contaminated material streams can be effectively processed, bypassing the need to install two separate melt filters and a melt pump between them, or two separate extruders. Recyclers not only avoid a higher investment but also a longer residence time of the melt in the different parts of the line which could take to degradation issues caused by prolonged friction.

It is in fact proven that processing plastic waste at lower temperatures, lower pressure levels and shorter residence times leads to superior quality of the final product. FIMIC is specifically concentrating to reach such levels with post-consumer material streams, by keeping an eye on low operational costs, which is one of the many advantages of FIMIC range of products.



Pre-sorted LLDPE stretch unwashed FIMIC ERA 500

By placing a first screen and a second finer screen in the second filtration chamber, recyclers can obtain a pre-filtration in the first scraping chamber of the ERA Filter and discharge the contamination from the first discharge valve. The same can be done with the contamination left on the second screen, by discharging it from a second discharge valve (independent from the first one and placed at the bottom of the melt filter). Being the two discharge valves independent, the one on the second chamber works at a slower pace and will discharge much less material compared to the first one.

This new FIMIC technology allows to process heavily contaminated plastic waste streams, with only one machine and two filtration steps, by using a much cheaper filtering screen to filter out the coarser (and usually the most dangerous) impuri-



Pre-sorted LLDPE stretch unwashed other filter

ties to then proceed to a finer filtration screen (i.e. the most expensive one).

FIMIC's Melt Filter ERA represents a significant advancement in plastics recycling technology, offering a solution to some of the industry's most pressing challenges. With its automatic operation, self-cleaning system, and ability to handle high contamination levels, the ERA melt filter is setting new standards for efficiency, quality, and versatility in the recycling process. As the demand for high-quality recycled plastics continues to grow, the ERA is poised to play a crucial role in the industry's efforts to achieve sustainability and reduce plastic waste.

FIMIC srl

Via Ospitale 44, 35010 Carmignano di  
Brenta (PD), Italy  
www.fimic.it

# Innovative Plastic Film Material Made from PLA Bioplastic

*Flexible, disposable plastic films used in shopping or garbage bags are made mainly from petroleum-based low-density polyethylene (LDPE). These films, however, come with a large carbon footprint and contribute to environmental pollution. A team from the Fraunhofer Institute for Applied Polymer Research IAP has now developed a flexible and recyclable plastic film material based on polylactide (PLA) bioplastic and paved the way for its commercialization. Their efforts have earned the researchers the Joseph von Fraunhofer Prize for 2024.*

**R**ecycling and defossilization play a crucial role when it comes to sustainable plastics. After use, plastics are ideally broken down into their basic components, which are used to produce new plastics with the same properties. However, part of the material is lost in the cycle of production, use and reuse. "To further advance the circular economy, these losses must be offset by non-fossil raw materials. This, however,

poses a challenge since there are usually not any bio-based counterparts for fossil plastics with the same material properties," says Dr. Antje Lieske, Head of the Polymer Synthesis department at Fraunhofer IAP in the Potsdam Science Park. "Although these properties can be improved through various additives, these interfere with recycling processes further down the line. In addition, they can be expensive and harmful to the



The researchers in their lab: Dr. Antje Lieske, Dr. Benjamín Rodríguez and André Gomoll from Fraunhofer IAP (from left to right)

environment, and, above all, they are not bio-based,” Lieske adds.

#### Material and process development based on PLA

The biopolyester PLA is a promising approach to solving this problem: It is bio-based, biodegradable, easily recyclable and has one of the strongest market potentials when it comes to bioplastics. Due to its high stiffness, it is perfectly suited for rigid packaging such as disposable cups – but not for flexible disposable packaging such as shopping bags, which are one of the main sources of disposable plastic waste. Dr. Antje Lieske has solved this problem together with her colleagues André Gomoll and Dr. Benjamín Rodríguez at Fraunhofer IAP.

“We coupled plasticizers, so-called polyethers, directly with the polymer chain to make the material more

The new PLA material can be processed into plastic films in a similar way to LDPE using conventional processing plants (Pictures: © Fraunhofer: Piotr Banczerowski)



flexible over the long term. Polyethers are non-toxic, commercially available and can also be produced from bio-based raw materials. Until now, plasticizers have been mixed into PLA as additives. However, the plasticizer molecules migrate out of the material over time, making the PLA stiff and rigid again. To prevent this migration, we anchored the polyether to the polymer. To achieve this, we synthesized PLA-based block copolymers in which the polyether chain segment is covalently linked to PLA chain segments at both ends,” explains Dr. Benjamín Rodríguez.

#### Sustainable and flexible plastic with great potential

The result is a novel, flexible PLA material that does not contain migrating plasticizers and, unlike LDPE, is at least 80 percent bio-based. “In the long term, we might be able to increase this proportion to almost 100 percent,” Gomoll explains. “In addition, our material can be produced cost-efficiently from commercially available raw materials in a simple synthesis process. This process does not require large-volume synthesis plants but can be implemented locally by medium-sized companies as a continuously operated process. Until now, PLA could only be produced profitably in continuous large-scale plants, which excluded smaller companies as manufacturers. Finally, the new PLA material can also be processed into plastic films using conventional processing equipment in a similar way to LDPE – and it can be chemically recycled with considerably less energy input than LDPE,” Gomoll continues.

These unique material properties prompted the Polymer-Group company to commercialize the material. In 2023, SoBiCo GmbH, a subsidiary of the Polymer-Group, commissioned a production plant for the new PLA block copolymers in Pferdsfeld (western Germany). It produces 2,000 tons of the new bioplastics per year under the name Plactid®. In the long term, it is set to produce 10,000 tons of the new flexible PLA material each year.

The new class of bioplastics will make an important contribution to making plastic packaging materials more sustainable. In addition to flexible packaging films, the new material might also tap into completely new use cases, e.g., in the automotive sector, in the textile industry and in additive manufacturing.

#### Joseph von Fraunhofer Prize

Since 1978, the Fraunhofer-Gesellschaft has awarded the annual Joseph von Fraunhofer Prize to its employees for outstanding scientific achievements in developing solutions for practical problems. This year, three prizes, each worth 50,000 euros, will be awarded to groups of researchers from different institutes.

Fraunhofer Institute for Applied Polymer Research IAP  
Potsdam Science Park, Geiselbergstr. 69,  
14476 Potsdam, Germany  
➔ [www.iap.fraunhofer.de](http://www.iap.fraunhofer.de)

# Optimising Production Efficiency through Precision and Automation

*In the dynamic world of manufacturing, precision control and automation are critical success factors. At iNOEX, we pride ourselves on helping leading companies meet these challenges. A particularly notable example is the work with K-FLEX Polska, a manufacturer of foam insulation (rubber, PE, mineral wool, polystyrene), multilayer PE-RT/Alu/PE-RT pipes, pre-insulated pipes and self-adhesive foils and tapes.*

**K**-FLEX is a multinational manufacturing company specialising in the production of flexible elastomeric thermal and acoustic insulation materials. The company has manufacturing facilities and a network of subsidiaries around the world. Its diversified product portfolio provides innovative solutions for many industries, including construction, transportation, petrochemical and renewable energy.

For over 30 years, K-FLEX products have been recognized in the insulation market for their high standards of INNOVATION, QUALITY and PERFORMANCE, playing a vital role in controlling energy consumption and reducing greenhouse gas emissions. K-FLEX's international production and wide distribution network provides customers with short distances to access customized services tailored to their specific needs.

## The Challenge

K-FLEX was faced with the challenge of optimizing its production processes and minimizing human error. In their search for the best solutions available on the market, they chose iNOEX technologies based on industry recommendations. Key to this decision was iNOEX's position as the market leader in dispensing systems for multilayer pipes. iNOEX's many years of experience and extensive expertise gave K-FLEX the confidence that they would be able to achieve their production goals efficiently and reliably. With iNOEX's advanced technologies, they have not only been able to improve the quality and consistency of their products but have also reduced production costs and significantly increased the efficiency of their operations. This has led to an overall increase in competitiveness and improved customer satisfaction.

## Finding the solution

K-FLEX now uses the iNOEX gravimetric and ultrasonic measuring systems. These systems have proven to be very accurate and reliable and provide perfect process control. The support during the purchase and project phase, as well as the subsequent commissioning, was a matter of course for iNOEX and the company is pleased that K-FLEX found this to be excellent and beyond their expectations.



*Tomasz Dużak (Manufacturing Director PE Plant, left) and Mateusz Kołodziejczak (Production Manager Pipes Dept, right)*

The implementation of the systems has had a significant impact on the partner's production processes, particularly in the field of automation. The ability to identify pipe size online and accurately control material usage ensures that production quality and efficiency is maintained at the highest level. This precise control not only reduces waste, but also significantly lowers production costs.

Another benefit is the increased flexibility in production. Thanks to the iNOEX solution, K-FLEX can react faster and more efficiently to market demands and customer requirements. The continuous monitoring and adjustment of production parameters in real time results in consistently high product quality and minimizes the risk of production errors.

## Everything under control with automation

iNOEX's automation and advanced systems have enabled K-FLEX to minimize production errors and significantly increase the efficiency of their production line, allowing them to deliver the highest quality products to their customers while remaining competitive. This collaboration is an impressive demonstration of how the technologies can help optimize production processes.

# Market Launch of the KNC-401 Online Thickness Sensor for Blown Film Lines

*How do you manage to fly over a wobbling bubble of film with a capacitive thickness sensor at a distance of a few tenths of a millimeter, measure its thickness with micrometer precision and leave no traces behind? KÜNDIG CONTROL SYSTEMS (KCS), a specialist division of Hch. HCH. KÜNDIG & CIE.AG (HKC), has been tackling this challenge for over 20 years and is about to launch its latest film thickness sensor, the KNC-401.*

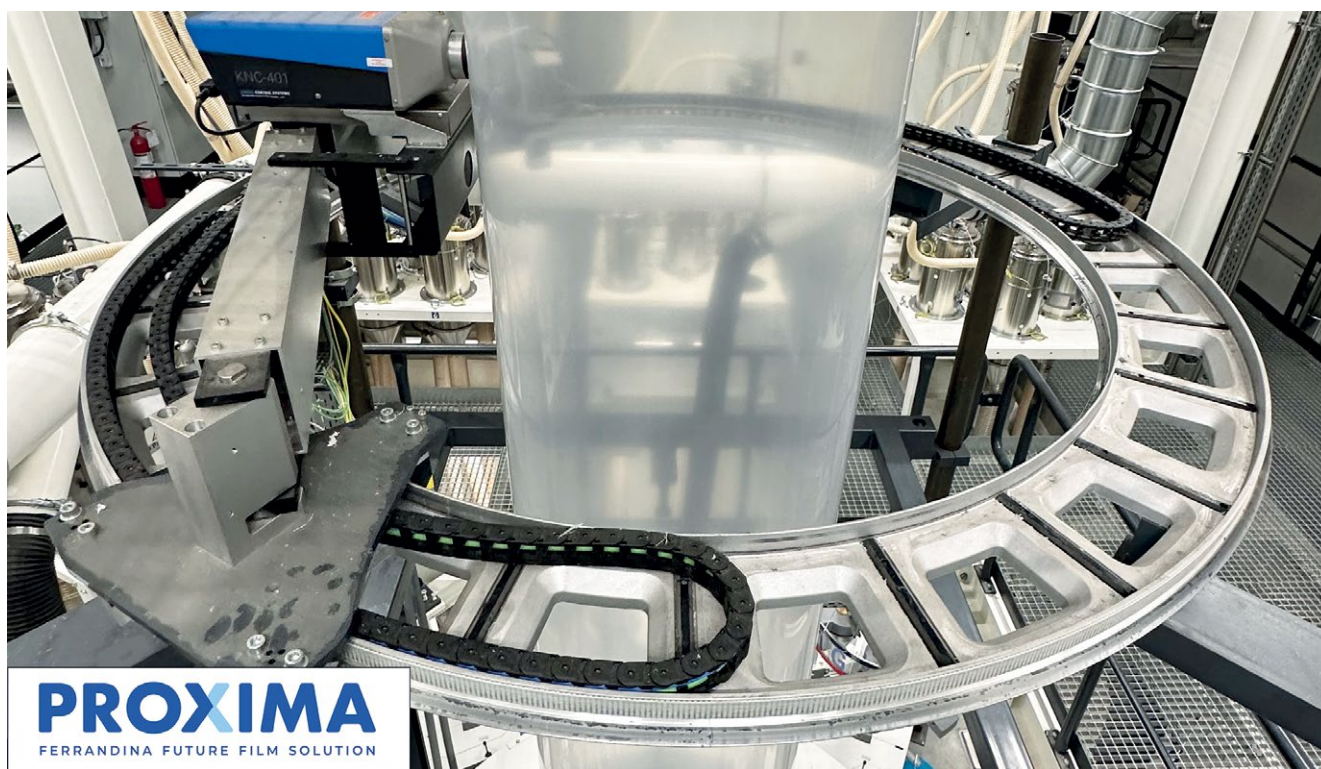

**PROXIMA**  
FERRANDINA FUTURE FILM SOLUTION

**H**igh-precision, fast online thickness measurement on the cylindrical film bubble is the cornerstone of film production with optimum thickness tolerances. Capacitive thickness measurement is currently still the favored measurement method for films based on polyolefins and those with low proportions of polyamide, EVOH or similar. This is due to the measurement accuracy, the suitability for measuring colored films and the fact that the measurement process does not require a permit.

For micrometer-precise, largely non-contact, capacitive thickness measurement, the distance be-

tween the sensor surface and the film bubble must only be a few tenths of a millimeter. To achieve this, an air cushion is often created in the area of the measuring electrode by means of fine holes and the thickness sensor is pressed into the film. Especially when measuring the thickness of sticky or surface-sensitive outer layers, this method leads to bubbles or marks on the film surface. In addition, with such materials, the bubble is poorly stabilized by a non-contact calibration cage and the thickness sensor often loses contact with the film surface, resulting in zero measurements at these affected positions.

*KNC-401 Rotomat KT 3G  
(Source: Coopbox Group S.p.A.,  
Ferrandina, Italy)*

As a unique selling point, KCS offers a type of thickness gauge in which the sensor head follows the fluctuating film surface by means of a linear motor. This guarantees high-precision thickness measurement, minimizes the volume of compressed air needed to generate the air cushion and allows the control of the air cushion temperature. This temperature control of the air cushion reduces haze marks on high-gloss films, for example, in the best possible way.

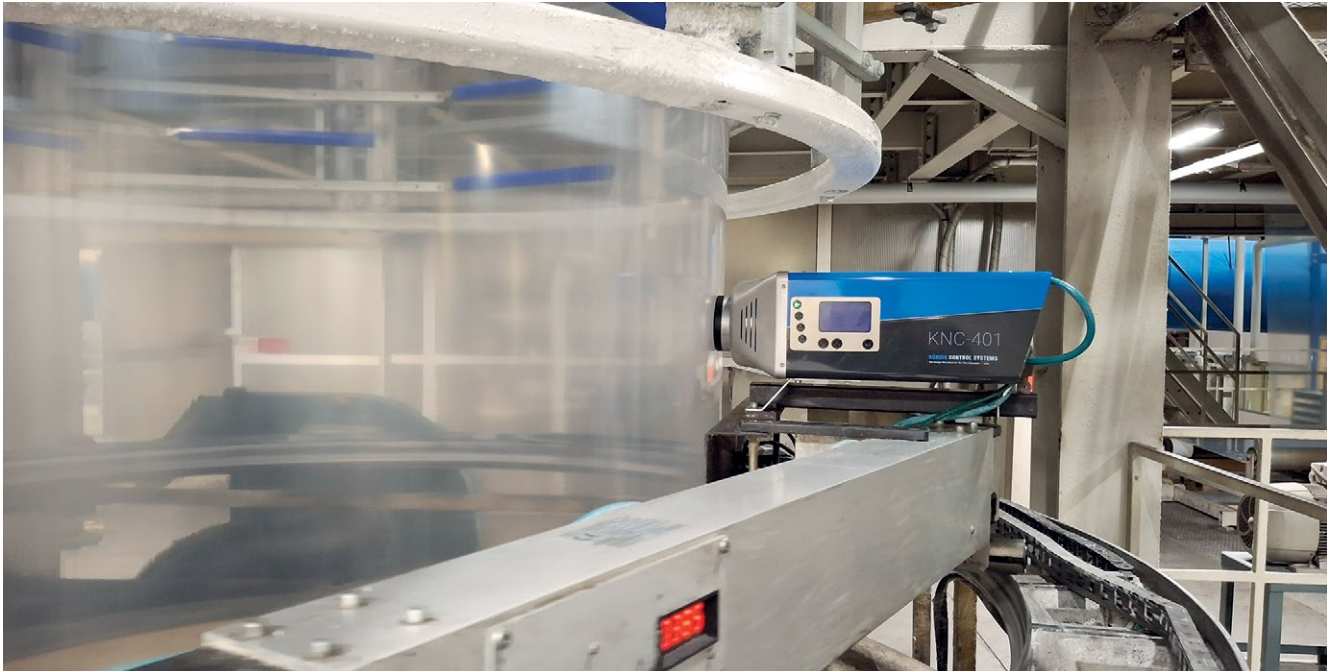

In 2010, KCS introduced the KNC-400 film thickness sensor, which works according to the above principle, to the global market. For the first two years, this sensor was mounted on a reversing device with telescopic radial adjustment and sold as a film thickness gauge with the designation KNC-400 Rotomat Synchro and KNC-400 Rotomat Vario. Since 2012, it has been mounted on the reversing device with articulated arm cross-beam with the model designations KNC-400 Rotomat KT 2G and KNC-400 Rotomat KT 3G.

Since the market launch of the KNC-400, the feedback from the hundreds of thickness sensors in daily production use have been incorporated into change requests for product improvements. Most of these have been implemented, but the KNC-400 still corresponds conceptually to the original development ideas.

Over the last decade, the output rates of blown film lines have multiplied and the demands on film quality – also for the reason to reduce the amount of raw materials used – have increased enormously. **KCS's mission is to enable the global film extrusion industry to a high quality, resource-saving and reliable production.** This mission statement obliges KCS to adapt its product range to the new customer requirements and five years ago launched

the project for the new development of all thickness sensors based on the capacitive measuring method.

The first step was to meticulously analyze the service and repair cases associated with the KNC-400 sensor over the past few years and incorporate these findings into the specifications for the new development of the successor sensor with the designation KNC-401. A great deal of attention was paid to improvements in terms of robustness, electromagnetic compatibility, modularity, reduction of compressed air consumption and the manufacturing and testing process. During the entire development cycle, the newly evaluated, externally procured components were subjected to various stress tests and, if necessary, replaced with other, more robust components.

Prototypes were tested in the best possible way on our in-house facilities and then handed over to selected end customers and OEMs for use on blown film lines. Based on the in-depth prototype tests, a pilot series of KNC-401 sensors was produced. Devices from the pilot series production were then put into daily production use at various film manufacturers and this experience was in turn incorporated into the series production of the KNC-401 sensors.

The market launch of this new generation of capacitive thickness

*KNC-401 Rotomat KT 2G  
(Source: Goglio S.p.A., Daverio, Italy)*

gauges has been delayed due to the pandemic and the subsequent procurement crisis. However, the time has now come and the KNC-401 sensor will be the first product available to the global market from the end of 2024 and will be sold as a new device with the designation KNC-401 Rotomat KT 3G. Thanks to its backwards compatibility, the KNC-401 sensor can also replace the predecessor model on existing measuring systems.

**The vision of KCS is to be the world's most trusted gauge manufacturer for film extrusion.** The company firmly believes that with the market launch of the KNC-401 sensor they are contributing to achieving this vision. KCS will also bring the remaining capacitive thickness sensors of the latest generation to production maturity as quickly as possible and distribute them to the global customer base.

**KÜNDIG CONTROL SYSTEMS (KCS), HCH.  
KÜNDIG & CIE. AG  
Joweid Zentrum 11,  
8630 Rütli ZH, Switzerland**

➔ [www.gauge.ch](http://www.gauge.ch)

# “Measuring Technology meets Gravimetric Weighing”

The companies SIKORA and ConPro have announced their strategic partnership under the slogan ‘Measuring technology meets gravimetric weighing’. Tube and pipe manufacturers now benefit from the possibility to directly combine measuring systems from SIKORA with gravimetric systems from ConPro, which further increases efficiency and quality in tube and pipe production.

The integration of both systems is made possible by a new interface developed by our experts. This is based on the latest industrial communication standards and ensures seamless communication between the SIKORA dimensional measuring device and the ConPro gravimetric system. During production, the measured tube or pipe parameters such as diameter, 360° wall thickness distribution, and ovality are continuously compared by the SIKORA measuring system. Additionally, the weight per meter can be quickly adjusted in real time

For maximum efficiency and quality, the graphical integration of ConPro gravimetry into the SIKORA ECOCONTROL 6000 user interface offers intuitive and simple handling

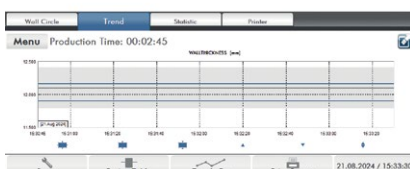
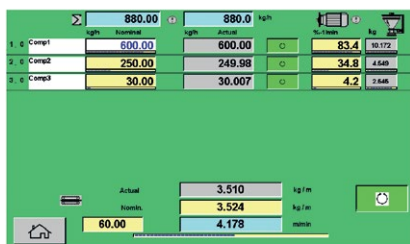

with the gravimetric system, allowing for precise control of the minimum wall thickness, maximum material savings, and guaranteed compliance with the product specification.

The graphical integration of ConPro gravimetry into the SIKORA ECOCONTROL 6000 user interface enables very simple and intuitive operation. Both systems work in real time, which enables an immediate reaction to process deviations. In extrusion lines with existing ConPro gravimetry and new lines, the SIKORA measuring device can be connected directly to the ConPro gravimetry via the new interface without having to go through an extruder control.

“We are very pleased about the cooperation with ConPro”, says Holger Lieder, Executive Board at SIKORA AG. “ConPro has been a leading and renowned supplier of gravimetric systems for the continuous weighing and dosing of raw materials for many years. Tube and pipe manufacturers who use our measuring devices can now intelligently combine them with ConPro's gravimetry and benefit from the advantages.”

Andreas Meyer zu Küingdorf, General Manager at ConPro, adds: “The partnership with SIKORA gives tube and pipe manufacturers the opportunity to combine gravimetry and dimensional measuring systems. Both systems complement



The new partnership between SIKORA and ConPro creates an interface between measuring technology and gravimetric weighing

each other and ensure consistently high tube or pipe quality. Material and costs are also saved.”

## The advantages at a glance:

- Combination of SIKORA dimensional measuring system with the ConPro gravimetry
- Intelligent interface based on the latest industrial communication standards for continuous data exchange
- Control of the minimum wall thickness for highest tube or pipe quality, as well as material and cost savings
- Integration of ConPro gravimetry with a SIKORA measuring system in existing or new lines
- Intuitive display and control of the tube or pipe parameters on the SIKORA ECOCONTROL 6000 or (optionally) on machine operating panels.

SIKORA AG  
Bruchweide 2, 28307 Bremen, Germany  
[www.sikora.net](http://www.sikora.net)



# “Primary Focus is on Circular Economy Solutions”

*An Interview with Mr. Cliff Zhang, Head of Foam Division, Vice President, Useon Technology Limited, at Chinaplas 2024*

**M**r. Zhang, we notice that the first and second days of the Chinaplas trade fair are quite busy. Could you please share a few words about your focus and key areas of interest at Chinaplas?

Our company focuses on five main areas. The first one is compounding. We specialize in twin-screw extruders designed for polymer compounding. As the second we can name foam extrusion. We offer commercialized foam extrusion products including XPS, XPET, and EPLA. Additionally, we produce other foam extrusion products such as XPE. The third one is polyolefin pelletizers. Our extruders are known for their high capacity, typically exceeding 20 tons per hour. As for the fourth, it is circular economy: We employ model-to-model technology for EPS and other circular solutions, enhancing sustainability. The fifth one is sheet-directed extrusion:

Our advanced technology simplifies PET sheet production by eliminating the need for pre-drying. Instead of the traditional two-step process, we directly feed PET chips or flakes into our twin-screw extruder, producing PET sheets efficiently.

*Which visitors are you hoping to connect with at Chinaplas, and from which countries do you expect them to come? Additionally, what are the most appealing exhibits for them at the fair?*

Our primary customers are from the Middle East and Eastern Europe, including Turkey, Saudi Arabia, Romania, Bulgaria, and Greece. In recent years, we’ve also seen increasing interest from Western Europe, including the UK, Switzerland, Spain, and Portugal.

Our cost-effective solutions are particularly attractive to these customers. For instance, our foam ex-

trusion machines are often priced at less than 50% of European machines. We have customers who compare our machines with high-end German models and find no significant difference in the final product, which leads them to purchase more from us due to the cost savings.

Additionally, our service and spare parts availability stand out. We maintain high standardization and keep a large stock of parts – such as 300 or 400 different diameters – that are often not readily available in Europe. We achieve this by delivering seven to eight lines per year and preparing two or three semi-finished products for quick shipment. In contrast, European companies may deliver only one or two lines annually and cannot afford to keep such a stock. Our ability to maintain inventory and deliver quickly sets us apart from our competitors.



Service is a crucial factor as it directly impacts the customer experience. When machines are comparable, exceptional service can set you apart from competitors. This is where we excel compared to European companies. We have a larger team of service engineers and local partners in various regions, including Brazil, the UK, India, and Turkey.

In these locations, we maintain service offices and small warehouses stocked with essential spare parts, such as screw elements and shafts. This local presence ensures we can provide prompt support and reduce downtime for our customers.

Although we are a Chinese company, we are committed to the international market and strive to operate as a global enterprise. We source many components from Europe, including gearboxes, shafts, and steel from Germany. Unlike many Chinese companies that focus on in-house production to save costs, we believe in leveraging international expertise. For instance, we use European sensors, blowing agents, pumps, and mass flow meters in our machines, which are then exported back to Europe. This approach underscores our commitment to being a truly international company.

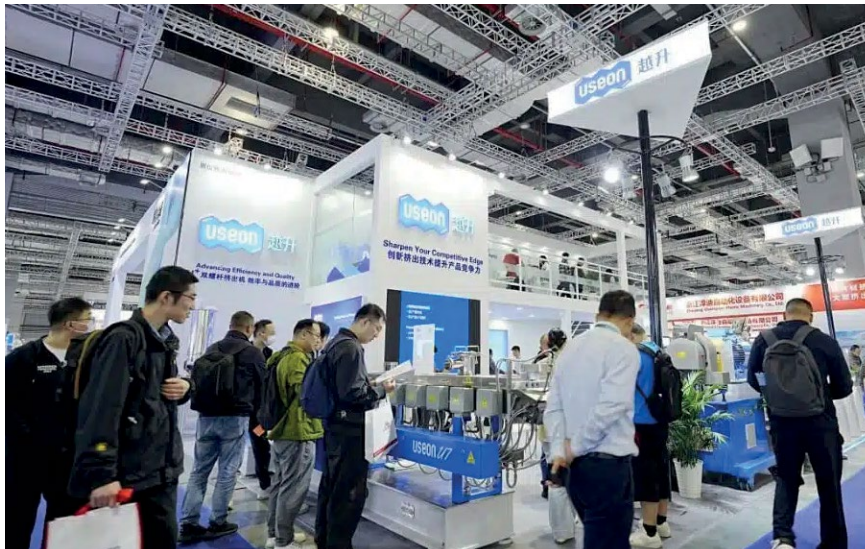

*How are you finding the trade show?*

We appreciate the trade show for its international scope. With over 50% of our market outside China, we value events like this, which is the largest in China and possibly the second largest in the world. From my experience, over 20% of the visitors to our booth are international, and more than 70% are returning customers.

*What are your upcoming plans for expanding your global market presence or advancing your technologies?*

Our primary focus is on circular economy solutions. We recently introduced our EPS-to-EPS technology last year, but we haven't yet received many orders. This technology is quite promising, especially given the prevalence of EPS waste in home packaging. While most EPS is typically repurposed for other applications, such as IPS or other extrusion processes, our technology can recycle EPS back into EPS. This approach enhances its value and supports a circular polystyrene system, a solution that has not been widely implemented before.

**USEON**

➔ [www.useon.com](http://www.useon.com)

# INTERNATIONAL CONFERENCE plast invest istanbul

December **3** + 2024  
ISTANBUL + TURKEY

on the eve of  
**Plast Eurasia**  
istanbul

**BONUS**  
December **4** + Old Istanbul **CITY TOUR**

## KEY TOPICS

- ◆ Investment strategies for the plastics processing sector in the current environment
- ◆ New capabilities of equipment
- ◆ Vital logistical problems and solutions proposed by companies
- ◆ Smart equipment – what does it mean to an investor?
- ◆ Digitalization and automation — what are the ways to make it economically efficient?
- ◆ Modern polymer materials and additives
- ◆ Added functionality in the segment of inline quality control at production facilities

Languages:  
English

Learn more



## CONTACTS

Alla Kravets

+49 1749 51 13 21

a.kravets@vm-verlag.com

istanbul.extrusion-info.com

# SMART EXTRUSION

**THE SPECIALIZED WEBPORTAL  
ON EXTRUSION  
FOR EVERY MODERN NEED**

**VM** Verlag GmbH  
Cologne, Germany



[www.smart-extrusion.com](http://www.smart-extrusion.com)